

Research Article

# Control of Aldehydes with Copper Coated Four Stroke Spark Ignition Engine with Gasohol with SCR Technique

Y. Nagini<sup>1</sup>, Maddali V.S. Murali Krishna<sup>2\*</sup>, S. Naga Sarada<sup>3</sup> and Machiraju Aditya Seshu<sup>4</sup>

<sup>1,2,4</sup>Mechanical Engineering Department, Chaitanya Bharathi Institute of Technology, Gandipet, Hyderabad- 500 075, India

<sup>3</sup>Mechanical Engineering Department, College of Engineering, JNT University, Hyderabad- 500 007, India

Accepted 15 June 2016, Available online 21 June 2016, Vol.6, No.2 (June 2016)

## Abstract

The invention of IC engines revolutionized the living habits of people to a great extent in particular petrol engines, which offer mode of individual transport. Indeed the petrol engine powered automobile and diesel engine powered buses and trucks are the symbols of our modern technological society. Four stroke engines offer many advantages like higher thermal efficiency, volumetric efficiency than two stroke engines. In the scenario of depletion of fossil fuels, the search for alternative fuels has become inevitable. Alcohols, the renewable fuels are important substitutes of gasoline, as their properties are comparable to gasoline fuels. However, for alcohol engines, aldehyde levels should be checked. These aldehydes are responsible for pungent smell of the engine and affect the human beings when inhaled in the large quantities. The volatile aldehydes are eye and respiratory tract irritants. Though Government legislation has not been pronounced regarding the control of aldehyde emissions, when more and more alcohol engines are coming to existence, severe measures the controlling of aldehydes emitted out through the exhaust of the alcohol run engines will have to be taken as serious view. Aldehyde levels were controlled by selective catalytic reduction technique. The emissions from gasoline engine were controlled by change of engine configuration (conventional engine to copper coated engine), fuel (gasoline to ethanol blended with gasoline of 20% by volume) and with provision of catalytic converter. Copper coated engine (CCE) showed reduction of aldehyde levels in comparison with CE with test fuels.

**Keywords:** Alternative fuels, CE, CCE, Selective Catalytic Reduction Technique

## Introduction

The invention of IC engines revolutionized the living habits of people to a great extent in particular petrol engines, which offer mode of individual transport. Indeed the petrol engine powered automobile and diesel engine powered buses and trucks are the symbols of our modern technological society. Four stroke engines offer many advantages like higher thermal efficiency, volumetric efficiency than two stroke engines. In the scenario of depletion of fossil fuels, the search for alternative fuels has become inevitable.

In the scenario of fast depletion of fossil fuels, ever increase of pollution levels with fossil fuels and increase of burden on developing countries like India, the search for alternative fuels has become pertinent apart from effective fuel utilization which has been the concern of the engine manufacturers, users and researchers involved in combustion & alternate fuel research. Alcohols are found to be the better alternate fuels for spark ignition engine, as the properties of alcohols are very close to those of gasoline [Heywood,

1988]. In addition, no major modification in the engine is required if low quantities of ethanol/methanol are blended with gasoline in spark ignition engine. Ethanol has higher C/ (C= Number of carbon atoms, H= Number of hydrogen atoms) ratio which leads to form water vapor during combustion. It has oxygen molecule in its composition. Theoretical air fuel ratios are less for ethanol when compared with gasoline operation. Hence ethanol blended with gasoline can be effectively used as fuel in SI engine.

Many researchers conducted experiments with blends of alcohol with gasoline in conventional SI engine. [Al-Farayehi *et al*, 2004; Abu Ziad *et al*, 2004; Ceviz *et al*, 2005; Nakata, 2006; Pearson, 2007; Bahattin *et al*, 2008]. They reported that performance improved with alcohol operation over gasoline operation. Ethanol blended gasoline [gasoline blended with ethanol, 20%, by vol] improved engine performance and decreased pollution levels when compared with neat gasoline on CE [Murali Krishna *et al*, 2008; Murali Krishna *et al*, 2011; Indira Priyadarsini *et al*, 2013]. Engine modification with copper coating on piston crown and inner side of cylinder head improves engine performance as copper is better conductor of heat and good combustion was achieved

\*Corresponding author: Maddali V.S. Murali Krishna

with copper coating. [Dandapani *et al*, 1991; Nedunchezian *et al*, 2000]. If the engine is run with alcohol, aldehydes should be checked. These aldehydes are carcinogenic in nature and once they are inhaled, cause severe headache and vomiting sensation. [Khopkar, 2004, Sharma, 2005]. Aldehyde vapors effects on human health include irritation of eye, throat, nose, asthma, pulmonary function. Thresholds for sensory irritation determined by controlled exposure studies, are reported as 0.6-1.2 mg/m<sup>3</sup> [0.5-1.0 ppm] (formaldehyde) and 90 mg/m<sup>3</sup> [50 ppm] (acetaldehyde) [Sharma, 2005]. These levels are substantially higher than the generally reported ambient air concentrations of these vapors Aldehydes are partially oxygenated organic compounds containing carbonyl group. An aldehyde functional group consists of a carbon atom bonded to a hydrogen atom double-bonded to an oxygen atom (O=CH-). Aldehydes were controlled in four stroke SI engine using catalytic converter with sponge iron as catalysts. [Kishor *et al*, 2010, Murali Krishna *et al*, 2010; Murthy *et al*, 2011, Indira *et al*, 2014; Nagini *et al*, 2014]. However, control of aldehyde emissions with zeolite in SI engines was not sufficiently reported in literature. Hence control of these emissions is immediate and an urgent task.

### Manufacturing of Ethanol [Hewood, 1988]

Ethanol is produced from organic materials such as grains, fruit, wood and even municipal solid wastes and waste or specifically grown biomass. The municipal solid wastes can be converted to alcohol. The wastes are first shredded and then passed under a magnet to remove ferrous materials. The iron free wastes are then gasified with oxygen. The product synthesis gas is cleaned by water scrubbing and other means to remove any particulates, entrained oils, H<sub>2</sub> S and CO<sub>2</sub>. CO-shift conversion for H<sub>2</sub> / CO / CO<sub>2</sub> ratio adjustment, alcohol synthesis, and alcohol purification are accomplished. Ethanol is renewable in nature. They have oxygen in their molecular composition. They have low C/H value. It has a low stoichiometric air fuel ratio. Its properties are suitable as blended fuel in spark ignition engine. Ethanol is renewable in nature. They have oxygen in their molecular composition. They have low C/H value. It has a low stoichiometric air fuel ratio. Its properties are suitable as blended fuel in spark ignition engine. The properties of test fuels are shown in Table.1. [Nagini *et al*, 2014].

**Table 1** Properties of Test Fuels [Nagini *et al*, 2014]

Property	Test Fuel		Test Method
	Gasoline	E-20	
Low Calorific Value (MJ/kg)	44.133	40.672	ASTM D340
Reid vapor pressure (kPa)	35.00	54.61	ASTM D323
Research Octane Number	84.8	93.4	ASTM D2699
Density at 15.5°C (kg/l)	0.7678	0.7782	ASTM D1298
Latent Heat of Evaporation (kJ/kg) at 15.5°C	600	650	

However, the excess vapor pressure as noticed from Table.1 with alcohol blends can lead to vapor problems (drivability problems), difficulties with hot starts, stalling, hesitation, and poor acceleration. It is possible to add high vapor pressure liquids or gases such as butane either generally or preferably during cold start situations. Either gasoline or LPG could be injected at cold starts to accomplish the same effect.

### Operating conditions

Test fuels used in the experimentation were neat gasoline, gasohol(ethanol 20% by volume blended with gasoline). Different combustion chambers used in the investigations were conventional engine combustion chamber and copper coated combustion chamber.

### Materials and methods

Fig.1 shows experimental set-up used for investigations. A four- stroke, single-cylinder, water-cooled, SI engine (brake power 2.2 kW, rated speed 3000 rpm) is coupled to an eddy current dynamometer for measuring brake power. Compression ratio of engine is varied (3 -9) with change of clearance volume by adjustment of cylinder head, threaded to cylinder of the engine. Engine speeds are varied from 2400 to 3000 rpm. Exhaust gas temperature is measured with iron- constantan thermocouples. Fuel consumption of engine is measured with burette method, while air consumption is measured with air-box method. In catalytic coated engine, piston crown and inner surface of cylinder head are coated with copper by plasma spraying. A bond coating of Ni-Co-Cr alloy is applied (thickness, 100 μ) using a 80 kW METCO plasma spray gun. Over bond coating, copper (89.5%), aluminium (9.5%) and iron (1.0%) are coated (thickness 300 μ). The coating has very high bond strength and does not wear off even after 50 h of operation [Dandapani *et al*, 1991]. with burette method, while air consumption is measured with air-box method. In catalytic coated engine, piston crown and inner surface of cylinder head are coated with copper by plasma spraying. A bond coating of Ni-Co-Cr alloy is applied (thickness, 100 μ) using a 80 kW METCO plasma spray gun. Over bond coating, copper (89.5%), aluminium (9.5%) and iron (1.0%) are coated (thickness 300 μ). The coating has very high bond strength and does not wear off even after 50 h of operation [Dandapani *et al*, 1991]. DNPH method (dinitrophenyl hydrazine) [8] was employed for measuring aldehydes in the experimentation. The exhaust of the engine was bubbled through 2,4 DNPH solution. The controlled flow rate (2l/m) was maintained by rotometer and then it was purified by means of filter, and then heated to 140° C with heater before sending it to DNPH solution. The hydrazones formed were extracted into chloroform and were analyzed by employing high performance liquid chromatography (HPLC) to find the percentage concentration of formaldehyde and acetaldehyde in the exhaust of the engine. The advantage of this method

over other methods is it can simultaneously measure formaldehydes and acetaldehydes. In order to reduce aldehydes in the exhaust of the engine, selective catalytic reduction technique was used.

The catalyst was prepared by using zeolite and lanthanum ion salt. Ion exchange was done by stirring 500 grams of zeolite in a 2N solution of lanthanum (III) salt for 5-6 hours at 70–80°C. [Herzog *et al*, 1992; Ghosh *et al*, 1997; Lin *et al*, 2005; Janardhan *et al*, 2012]. Ion exchanged zeolite was recovered by filtration and activated by calcinations in an oven at 400°C for 3 hours and was furnace cooled to retain mechanical properties. Modified zeolite (Catalyst-B) so obtained was placed in catalytic chamber which had a cylindrical shape with a diameter of 120 mm and length 600 mm. Infusion of urea on lanthanum exchanged zeolite (catalyst-C) was made by gravity feed dosing system. A nozzle was used to generate fine spray of urea solution into exhaust gas before it entered into catalytic chamber containing lanthanum exchanged zeolite. NO<sub>x</sub> emissions were controlled with use of different catalysts in both versions of the engine at peak load operation of the engine. Formaldehyde and acetaldehyde levels were measured under three different operating conditions. Set-A represents without catalyst, Set-B represents use of Catalyst-B (modified zeolite) and Set-C denotes use of Catalyst-C (lanthanum exchanged zeolite with urea infusion)

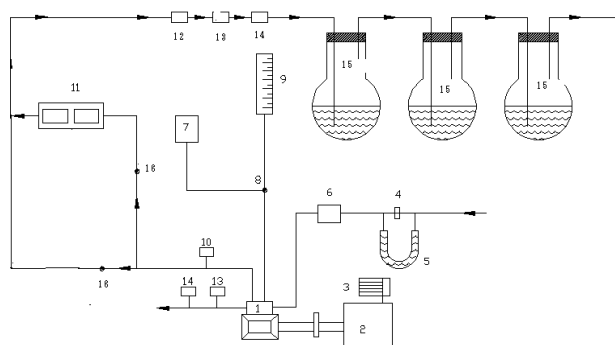

1.Engine, 2.Eddy current dynamometer, 3. Loading arrangement, 4. Orifice meter, 5. U-tube water monometer, 6. Air box, 7. Fuel tank, 8. Three-way valve, 9. Burette, 10. EGT Indicator, 11. Catalytic converter, 12. Filter, 13. Rotometer, 14. Heater, 15. Round bottom flask containing DNPH solution 16. Directional valve.

**Fig.1** Experimental Set Up

## Results and discussion

The engine was operated on compression ratio of 9:1 and speed of 3000 rpm. Fig.2 presents bar charts showing the variation of formaldehyde levels with test fuels with different versions of the engine.

These aldehydes are responsible for pungent smell of the engine and affect the human beings when inhaled in the large quantities. The volatile aldehydes

are eye and respiratory tract irritants. Though Government legislation has not been pronounced regarding the control of aldehyde emissions, when more and more alcohol engines are coming to existence, severe measures the controlling of aldehydes emitted out through the exhaust of the alcohol run engines will have to be taken as serious view.

It is observed from Fig.2, that formaldehyde emissions were higher with ethanol blended gasoline operation in conventional engine. This was due to oxidation reaction of ethanol with hydro-carbon fuels. This was due to partial oxidation compared to neat gasoline. The low combustion temperature lead to produce partially oxidized carbonyl (aldehyde) compounds with ethanol blended gasoline.

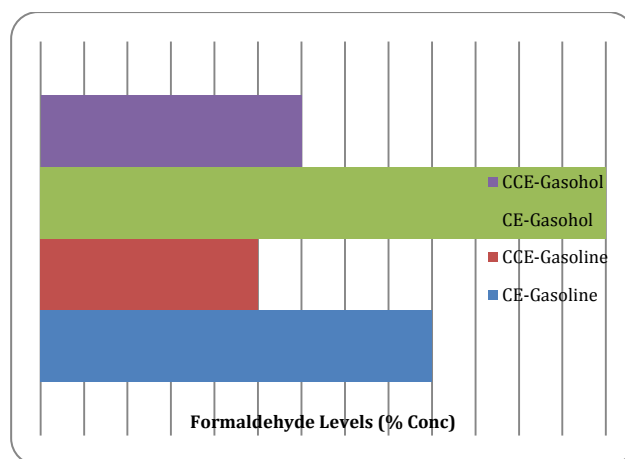

**Fig.2** Bar charts showing the variation of formaldehyde levels with different versions of the engine with test fuels

Formaldehyde emissions were quiet low with non-alcoholic fuels with engine with copper coated combustion chamber as noticed from the same Figure. CCE reduced formaldehyde emissions effectively with both test fuels. Improved combustion with catalytic activity of CCE eliminated partial compounds during combustion reactions and thus reduced formaldehyde emissions.

Table.2 shows data of aldehyde emissions with test fuels with different catalysts. Set-B operation of the catalytic converter decreased formaldehyde emissions by 30% when compared with Set-A operation with test fuels. This was due to improved oxidation reaction of the catalyst. Set-C operation of the catalytic converter decreased formaldehyde emissions by 60% when compared with Set-A condition of the catalytic converter. Zeolite with urea infusion was proved to be efficient in reducing formaldehyde emissions due to its large surface area.

**Table 2** Data of ‘formaldehyde concentration (%) with different test fuels with different configurations of the engine at different operating conditions of the catalytic converter with different catalysts

Formaldehyde Emissions (% Concentration)				
Set	Conventional Engine (CE)		Copper Coated Engine (CCE)	
	Neat Gasoline	Ethanol blended gasoline (Gasohol)	Neat Gasoline	Ethanol blended gasoline (Gasohol)
Set-A	6.5	8.5	4.5	5.0
Set-B	4.5	5.9	2.5	3.0
Set-C	<b>2.5</b>	3.4	1.5	2.0

**Table 3** Data of Acetaldehyde concentration (%) with different test fuels with different configurations of the engine at different operating conditions of the catalytic converter with different catalysts.

Acetaldehyde (% Concentration)				
Set	Conventional Engine (CE)		Copper Coated Engine (CCE)	
	Neat Gasoline	Ethanol blended gasoline(gasohol)	Neat Gasoline	Ethanol blended gasoline(gasohol)
Set-A	8.5	12.1	5.1	7.3
Set-B	5.9	8.5	3.5	5.1
Set-C	<b>3.4</b>	4.8	2.0	2.9

Fig.3 presents bar charts showing the variation of acetaldehyde levels with test fuels with different versions of the engine. Acetaldehyde levels followed similar trends with formaldehyde levels with both versions of the engine with test fuels.

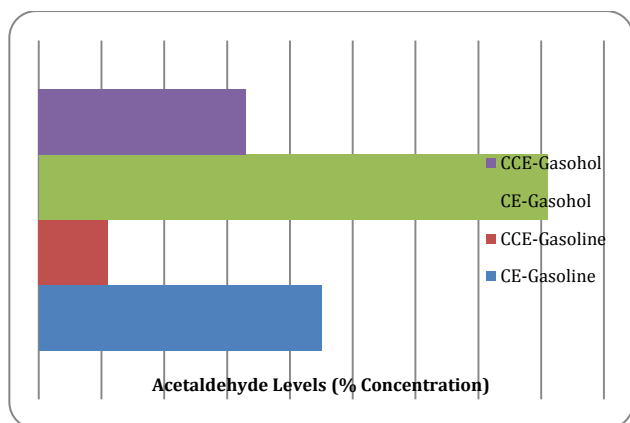

**Fig.3** Bar charts showing the variation of Acetaldehyde levels with different versions of the engine with test fuels

CCE decreased acetaldehyde levels effectively with both test fuels. Improved combustion with increased catalytic activity prevailing at high temperatures reduced partial compounds and thus eliminated acetaldehyde levels.

Table.3 shows data of acetaldehyde levels with test fuels with different versions of the engine with different catalysts. From Table.2, it is noticed that acetaldehyde emissions followed the similar trends with data of formaldehyde emissions in both versions of the combustion chamber. These emissions decreased considerably with Set-B operation with both versions of the combustion chamber with test fuels. Set-C operation further decreased these emissions

with test fuels in both versions of the combustion chamber. However, ethanol blended gasoline increased acetaldehyde emissions drastically when compared with gasoline operation on both versions of the combustion chamber. However, engine with copper coated combustion chamber decreased acetaldehyde emissions in comparison with CE with test fuels. This was due to improved combustion so that intermediate compounds will not be formed.

**Conclusions**

Without use of catalyst, formaldehyde emissions decreased by 30%, while acetaldehyde emissions decreased by 37% with CCE (engine with copper coated combustion chamber) in comparison with CE with neat gasoline operation. Formaldehyde emissions reduced by 40%, while acetaldehyde emissions reduced by 40% with CCE in comparison with CE with ethanol blended gasoline operation. Set-B operation (modified zeolite) reduced aldehyde levels by 30-35% while Set-C operation (urea infused lanthanum zeolite) decreased aldehyde levels by 60-65% in comparison with Set-A operation.

**Acknowledgements**

Authors thank authorities of Chaitanya Bharathi Institute of Technology, Hyderabad for facilities provided. Financial assistance from Andhra Pradesh Council of Science and Technology (APCOST), Hyderabad, is greatly acknowledged.

**References**

Heywood, J.B. 1988, Fundamentals of IC engines, TMH, NewYork  
 Al-Farayedhi, A. A., Al-Dawood, A. M. and Gandhidasan, P. 2004, Experimental investigation of spark ignition engine

- performance using oxygenated fuel, *ASME Journal of Engineering for Gas Turbines and Power*, 126, pp 178-191.
- Abu-Zaid., Badran, O. and Yamin, J. 2004, Effect of ethanol addition on the performance of spark ignition engines, *Energy & Fuels*, 18, pp 312- 315.
- Ceviz, M.A. and Yu ıksel, F., Effects of ethanol-unleaded gasoline blends on cyclic variability and emissions in a spark ignition engine, *Applied Thermal Engineering*, Volume- 25, 917-925, 2005.
- Nakata, K. 2006, The effect of ethanol fuel on a spark ignition engine, *SAE Paper* No-2006-01-3380.
- Pearson, R.J. 2007, Alcohol based fuels in high performance engines, *SAE Paper*, No - 2007-01-0056, 2007.
- Bahattin Celik, M. 2008, Experimental determination of suitable ethanol-gasoline blend rate at high compression ratio for gasoline engine, *Applied Thermal Engineering*, 28, pp396-404.
- Murali Krishna, M.V.S., and Kishor,K. 2008, Performance of copper coated spark ignition engine with ethanol-blended gasoline with catalytic converter, *Indian Journal (CSIR) of Scientific and Industrial Research*, 67,July,543-548.
- Murali Krishna, M.V.S., Kishor, K., Murthy, P.V.K., Gupta, A.V.S.S.K.S., and Narasimha Kumar,S. 2011, Comparative studies on performance evaluation of four stroke copper coated spark ignition engine with catalytic converter with alcohols. *International Journal of Advances in Engineering Research*, 2(6), 1-11.
- Indira Priyadersini, Ch., Murali Krishna, M.V.S., Naginii, Y., Ushasri, P., Krishna Murthy, P.V., and Kishor, K. 2013, Comparative studies on four stroke copper coated spark ignition engine with catalytic converter with different catalysts with alcohol blended gasoline. *International Journal of Management, IT and Engineering*, 3(5), 600-620
- Dhandapani, S. (1991), Theoretical and experimental investigation of catalytically activated lean burnt combustion, Ph D Thesis, IIT, Chennai.
- Nedunchezian, N., and Dhandapani, S. (2000), Experimental investigation of cyclic variation of combustion parameters in a catalytically activated two-stroke SI engine combustion chamber, *Engg Today*, 2,pp 11-18.
- Khopkar,S.M. 2004, Environmental Pollution Analysis,[New Age International (P) Ltd, Publishers, New Delhi], 180-190.
- B.K.Sharma. 2005, Engineering Chemistry, [Pragathi Prakashan (P) Ltd, Meerut], pp 150-160.
- M.V.S.Murali Krishna and K.Kishor. (2005). Control of pollutants from copper coated spark ignition engine with ethanol blended gasoline. *Indian Journal of Environmental Protection*, 25(8), August, 732-738.
- Kishor, K., Murali Krishna, M.V.S., Gupta, A.V.S.S.K.S., Narasimha Kumar,S., and Reddy,D.N. 2010, Emissions from copper coated spark ignition engine with ethanol blended gasoline with catalytic converter. *Indian Journal of Environmental Protection*, 30(3), pp 177-183
- Murali Krishna, M.V.S., Kishor, M.V.S., Gupta, A.V.S.S.K.S., Narasimha Kumar ,S., and Reddy, D.N.. 2010, Control of pollutants from copper coated spark ignition engine with gasohol. *Pollution Research*, 29(3),pp 391-395.
- Murthy, P.V.K., Narasimha Kumar, S., Kishor,K., and Murali Krishna, M.V.S., 2011, Aldehyde emissions from two-stroke and four-stroke spark ignition engines with catalytic converter running on gasohol. *International Journal of Fuels and Lubricants*, (Croatia), 50(2),pp 137-156.
- Nagini, Y., Murali Krishna,M.V.S. and Naga Sarada, S, 2014, Studies on exhaust emissions of a four-stroke spark ignition engine with gasohol with improved design of catalytic converter, *International Journal of Mechanical Engineering and Technology*, April, 5(4),72-82.
- Nagini, Y., Murali Krishna, M.V.S., and Naga Sarada, S. 2014,Control of aldehydes from four stroke spark ignition engine with copper coated combustion chamber with gasohol with improved design of catalytic converter, *International Journal for Advance Research in Engineering and Technology*, 2(4), 1-6.
- Herzog, P.P, et al., -NOx reduction strategies for DI diesel engine, SAE Paper No 920470, 1992.
- Ghosh, B.B. and Nag, P. 1997, NOx reduction in S.I. engine exhaust using zeolite with urea infusion, *Proceedings of 15th National Conference I.C Engines and Combustion*. Chennai, pp.357-362.
- Lin, H. and Steven, B.O. 2005, Reduction of NOx in diesel exhaust of gases and fuel injection systems, US Patent 6919047.
- Janardhan, N., Ushasri,P., Murali Krishna, M.V.S., and Murthy, P.V.K. 2012, Performance of biodiesel in low heat rejection diesel engine with catalytic converter. *International Journal of Engineering and Advanced Technology*, 2(2), pp 97-109.