

Research Article

Experimental Investigations on Performance Parameters of Diesel Engine with Ceramic Coated Insulated Combustion Chamber with Jatropa Oil with Varied Injection Pressure

N. Janardhan[†], Maddali. V.S. Murali Krishna^{**} and P.Usha Sri[‡]

[†]Mechanical Engineering Department, Chaitanya Bharathi Institute of Technology, Gandipet, Hyderabad 500075, Telangana State, India

[‡]Mechanical Engineering Department, College of Engineering, Osmania University, Hyderabad- 500 007, Telangana State, India

Accepted 10 June 2015, Available online 15 May 2015, Vol.5, No.2 (June 2015)

Abstract

Vegetable oils, which are renewable fuels, can be effectively used to combat fuels shortage in developing countries and at the same time bring back degraded lands into cultivation. Experiments were carried out to evaluate the performance of diesel engine with ceramic coated cylinder head with crude vegetable oil with varied injector opening pressure. Performance parameters [brake thermal efficiency, exhaust gas temperature, coolant load, volumetric efficiency and sound levels] were determined at various values of brake mean effective pressure (BMEP) of the ceramic coated combustion chamber and compared with neat diesel operation on conventional engine (CE) and vegetable oil operation at similar operating conditions. Engine with LHR-1 combustion chamber with vegetable oil operation showed improved performance at manufacturer's recommended injection timing of 27°bTDC, and the performance improved marginally with increased injector opening pressure and comparison with CE with diesel and vegetable oil at 27°bTDC.

Keywords: Vegetable oil; Fuel performance, Conventional engine, LHR engine

1. Introduction

Vegetable oils are important substitutes for diesel as their properties are comparable to diesel fuels. When Rudolph Diesel, first invented the diesel engine, about a century ago, he demonstrated the principle by employing peanut oil and hinted that vegetable oil would be the future fuel in the diesel engine [Avinash Kumar *et al*, 2009]. Several researchers experimented the use of vegetable oils as fuel on conventional engines (CE) and reported that the performance was poor, citing the problems of high viscosity, low volatility and their polyunsaturated character causing the problems of piston ring sticking, injector and combustion chamber deposits, fuel system deposits, reduced power, reduced fuel economy and increased exhaust emissions [Avinash Kumar *et al*, 2009; R.D.Mitra *et al*, 2010; No Soo Young, 2011; Avinash Kumar *et al*, 2013; N.Venkateswara Rao *et al*, 2013; D.Srikanth *et al*, 2013; Maddali Krishna *et al*, 2014; N.Durga Prasada Rao *et al*, 2014]. The presence of the fatty acid components greatly affects the viscosity of the oil, which in turn affect the wear of engine components, oil consumption, fuel economy, hot starting, cold starting, low temperature

pumpability, noise and shear stability. The limitation of unsaturated fatty acids is necessary due to the fact heating higher unsaturated fatty acids results in polymerization of glycerides. This can lead to formation of deposits or to deterioration of lubricating oil. The different fatty acids present in the vegetable oil are palmitic, steric, linoleic, and oleic fatty acids [Avinash Kumar *et al*, 2009]. These fatty acids increase particulate emissions and also lead to incomplete combustion due to improper air-fuel mixing. Studies were made with single cylinder, four-stroke water cooled direct injection diesel engine, with 3.68 kW brake power at a speed of 1500 rpm with a compression ratio of 16:1 with vegetable oils with varied injector opening pressure and injection timing. [N.Venkateswara Rao *et al*, 2013; D.Srikanth *et al*, 2013]. The injection timing was varied by inserting copper shims in between pump body and engine frame, while change of injector opening pressure was achieved by using nozzle-testing device. At manufacturer's recommended injection timing of 27° bTDC, thermal efficiency decreased by 10%, particulate emissions increased by 56%, while nitrogen oxide (NO_x) levels decreased by 18% with crude vegetable oil when compared with neat diesel operation on conventional engine. Particulate emissions decreased by 15–20%, while NO_x levels increased by 15–20%

*Corresponding author: Maddali. V.S. Murali Krishna

with conventional engine with crude vegetable oil operation with an increase of injector opening pressure of 80 bar, when compared with neat diesel operation.

Experiments were conducted on preheated vegetable oil in order to equalize their viscosity to that of pure diesel may ease the problems of injection process [N.Venkateswara Rao *et al*, 2013; D.Srikanth *et al*, 2013] investigations were carried out on conventional four stroke diesel engine, 3.68 kW at a speed of 1500 rpm with preheated vegetable oil with varied injection timing and injection pressure. It was reported that preheated vegetable oil at 27° bTDC, increased thermal efficiency by 3–4%, exhaust gas temperature by 4–5%, decreased particulate matter emissions by 8–9%, NO_x emissions by 5–6%, when compared with normal biodiesel.

Increased injector opening pressure may also result in efficient combustion in compression ignition engine. It has a significance effect on the performance and formation of pollutants inside the direct injection diesel engine combustion. Experiments were conducted on conventional four stroke diesel engine, with neat diesel operation with increased injector opening pressure. [I.Celikten, 2003; Y.Cingur *et al*, 2003; D.T. Hountalas *et al*, 2003; S.Jindal *et al*, 2010; Avinash Kumar *et al*, 2013]. They reported that performance improved marginally with an increase of injection pressure.

Experiments were conducted on conventional four stroke diesel engine, 3.68 kW at a speed of 1500 rpm with vegetable oil operation with increased injector opening pressure. They reported that performance of the engine improved with increased injector opening pressure with vegetable oil operation [N.Venkateswara Rao *et al*, 2013; D.Srikanth *et al*, 2013]. It increased thermal efficiency by 5–6%, decreased exhaust gas temperature by 8–10%, particulate emissions by 20–22% and increased NO_x levels by 10–14% with an increase of injector opening pressure by 80 bar.

The drawbacks associated with vegetable oils (high viscosity and low volatility) call for hot combustion chamber, provided by low heat rejection (LHR) combustion chamber. The concept of the engine with LHR combustion chamber is reduce heat loss to the coolant, by providing thermal resistance in the path of heat flow to the coolant. Any saving in this part of the energy distribution would either increase the energy lost through exhaust gases or increase the power output. Considerable efforts are under way to reduce heat loss to the coolant by various researchers. However, the results are a little confusing as to whether the insulation would improve or deteriorate thermal efficiency. Three approaches that are being pursued to decrease heat rejection are (1) Coating (low grade LHR combustion chamber) with low thermal conductivity materials on crown of the piston, inner portion of the liner and cylinder head, (2) air gap insulation (medium grade LHR combustion chamber) where air gap is provided in the piston and other

components with low-thermal conductivity materials like superni, cast iron and mild steel and (3). Combination of low grade and medium grade LHR combustion chambers results in high grade LHR combustion chamber.

Experiments were conducted with ceramic coated diesel engine with neat diesel operation [A.Parlak *et al*, 2005; B.Ekrem *et al*, 2006; M.Ciniviz *et al*, 2008; M.V.S.Murali Krishna *et al*, 2013]. They reported that brake specific fuel consumption decreased by 3–4%, exhaust gas temperature increased by 15%, volumetric efficiency decreased by 5–6% with engine with ceramic coated cylinder head in comparison with conventional engine.

Investigations were carried out with ceramic coated cylinder head with vegetable oils. [M.V.S.Murali Krishna *et al*, 2012; Ch.Kesava Reddy *et al*, 2012; D.Srikanth *et al*, 2013] They reported that low grade LHR engine with ceramic coated cylinder head with vegetable oils increased thermal efficiency marginally, reduced volumetric efficiency and increased exhaust gas temperatures. They further reported from their investigations, that thermal efficiency increased by 3–4%, volumetric efficiency increased by 2–3%, particulate emissions decreased by 20–25% NO_x levels decreased by 20–25%, peak pressure increased by 20–25% and maximum rate of pressure increased by 6–8% with engine with LHR combustion chamber with vegetable oil operation with an increase of injector opening pressure of 80 bar when compared with neat diesel operation on conventional engine at 27° bTDC.

Little reports were available on comparative studies of performance evaluation of low grade LHR engine with crude jatropha oil and diesel with varied injector opening pressure and at different operating conditions of the vegetable oil. The authors have made an attempt in this direction. Studies were made on low grade LHR engine consisted of ceramic coated cylinder head with different operating conditions of the crude vegetable oil with varied injector opening pressure and compared with vegetable oil with conventional engine.

2. Materials and Methods

2.1 Crude Vegetable Oil

India with just 2.4% of the global area supports more than 16% of world's human population and 17% of the cattle population. According to economic survey (2000–2001), of the cultivable land area, about 175 million hectares are classified as waste and degraded or marginal land. If the non forest waste-lands could be used to cultivate plants which can survive on such soil and which can produce oilseeds, these could be effectively used to combat fuels shortage in the country and at the same time bring such degrade lands back to its productive capacity.

Jatropha (*Jatropha curcas*, Ratanjyot) is a suitable candidate for its purpose. Jatropha oil known as moglaerand, beghierand, chandsaiyoti, or nepalam in

Table.1 Properties of Test Fuels

Test Fuel	Viscosity at 25°C (centipoise)	Specific gravity at 25° C	Cetane number	Lower Calorific value (kJ/kg)
Diesel	12.5	0.84	55	42000
Jatropha oil (crude)	125	0.90	45	36000
ASTM Standard	ASTM D 445	ASTM D 4809	ASTM D 613	ASTM D 7314

Table.2 Specifications of the Test Engine

Description	Specification
Engine make and model	Kirloskar (India) AV1
Maximum power output at a speed of 1500 rpm	3.68 kW
Number of cylinders ×cylinder position× stroke	One × Vertical position × four-stroke
Bore × stroke	80 mm × 110 mm
Method of cooling	Water cooled
Rated speed (constant)	1500 rpm
Fuel injection system	In-line and direct injection
Compression ratio	16:1
BMEP @ 1500 rpm	5.31 bar
Manufacturer’s recommended injection timing and pressure	27°bTDC × 190 bar
Dynamometer	Electrical dynamometer
Number of holes of injector and size	Three × 0.25 mm

India can be substituted for diesel. [M.V.S.Murali Krishna, 2004]. India imports jatropha oil of worth about 400 crores annually, which is used for making soap. Jatropha is a large shrub or small tree found throughout the tropical and subtropical regions of the world. The plant has several distinguishing and useful properties such as hardness, rapid growth easily propagation and wide ranging usefulness. It grows on any type of soil and is well adapted to cultivation. The plant has no major diseases or insect pests and is not browsed by cattle or sheep even during times of drought. The plant can survive for more than a year without water. Propagation is easily achieved by seed or stem cutting and its growth is rapid as is implied by its ability to form a thick live hedge nine months after planting. The plant starts yielding form the third year onwards and continues to yield for the next 25 years. The whole seeds can be crushed to yield about 25%oil. Double crushing can increase the yield to 28.5%and solvent extraction to 30%. The yield from established plantations in Brazil is around 1.5 to 2.3 tons per hectare. The seed and oil possess toxins and hence non-edible. The oil cake is also toxic and can be used only as manure and is very useful for this application with high nitrogen content and a favorable N: P: K ratio of 2.7:1.2:1. The properties of vegetable oil are shown in Table.1

2.2 Engine with LHR Combustion Chamber

Partially stabilized zirconium (PSZ) of thickness 500 microns was coated inside portion of cylinder head by means of plasma technique.

2.3 Experimental Set-Up

The schematic diagram of the experimental setup used for the investigations on the engine with LHR combustion chamber with cotton seed oil based biodiesel is shown in Fig.1.

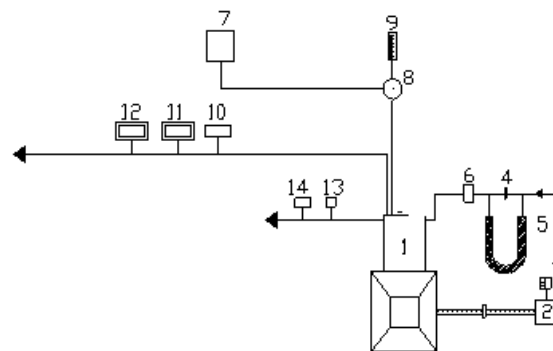

1.Engine, 2.Electical Dynamo meter, 3.Load Box, 4.Orifice meter, 5.U-tube water manometer, 6.Air box, 7.Fuel tank, 8, Three way valve, 9.Burette, 10. Exhaust gas temperature indicator, 11.AVL Smoke meter, 12.Netel Chromatograph NOx Analyzer, 13.Outlet jacket water temperature indicator and 14. Outlet-jacket water flow meter

Fig.1 Schematic diagram of experimental set-up

Specifications of the test engine were given in Table 2. The engine tests were carried out with a single-cylinder, four-stroke, naturally aspirated, compression ignition engine with brake power 3.68 k W at a speed of 1500 rpm. The compression ratio of engine was 16:1. Manufacturer’s recommended injection timing and injector opening pressure were 27° bTDC and 190 bar. The engine was connected to an electric dynamometer for measuring its brake power. Dynamometer was loaded by a loading rheostat. The

accuracy of engine load was ± 0.2 kW. The speed of the engine was measured with digital tachometer with accuracy $\pm 1\%$. The fuel consumption was registered with the aid of fuel measuring device (Burette and stop watch). The accuracy of brake thermal efficiency obtained is $\pm 2\%$. Vegetable oil was injected into the engine through conventional injection system. Provision was made for preheating of vegetable oil to the required levels (90°C) so that its viscosity was equalized to that of diesel fuel at room temperature.

Air-consumption of the engine was obtained with an aid of air box, orifice flow meter and U-tube water manometer assembly. Air-box with diaphragm was used to damp out the pulsations produced by the engine, for ensuring a steady flow of air through the intake manifold. The naturally aspirated engine was provided with water-cooling system in which outlet temperature of water was maintained at 80°C by adjusting the water flow rate. The water flow rate was measured by means of analogue water flow meter, with accuracy of measurement of $\pm 1\%$.

Engine oil was provided with a pressure feed system. No temperature control was incorporated, for measuring the lube oil temperature. Change of injector opening pressure from 190 bar to 270 bar (in steps of 40 bar) was made using nozzle testing device. The maximum injector opening pressure was restricted to 270 bar due to practical difficulties involved. Coolant water jacket inlet temperature, outlet water jacket temperature and exhaust gas temperature were measured by employing iron and iron-constantan thermocouples connected to analogue temperature indicators. The accuracies of analogue temperature indicators are $\pm 1\%$. Engine radiated sound pressure was measured with the help of sound level meter (B & K type 2238) at a distance of 1 m on the exhaust side of the engine as per engine sound level measurement procedure SAE J1074 at full load operation of the engine. A typical meter consists of a microphone for picking up the sound and converting it into an electrical signal, followed by electronic circuitry for operating on this meter. The accuracy of measurement of sound levels is ± 2 decibels. Analyzers were allowed to adjust their zero point before each measurement. To ensure that accuracy of measured values was high, the gas analyzers were calibrated before each measurement using reference gases.

3. Results and Discussion

Various performance parameters studied were brake thermal efficiency, brake specific energy consumption, exhaust gas temperature, sound levels and volumetric efficiency

Fig.2 shows variation of brake thermal efficiency with brake mean effective pressure in conventional engine at different injection timings with crude jatropha oil operation. Similar characteristics with neat diesel operation on conventional engine at recommended injection timing was also shown for comparison purpose. Conventional engine with crude

vegetable oil showed the deterioration in the performance at all loads when compared with the neat diesel operation on conventional engine at recommended injection timing.

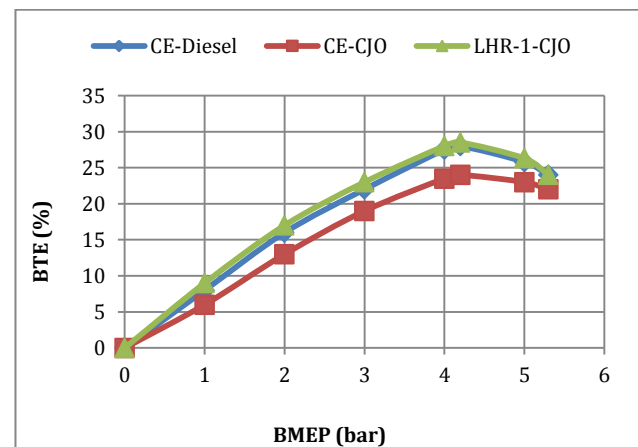

Fig.2 Variation of brake thermal efficiency (BTE) with brake mean effective pressure (BMEP) in conventional engine (CE) and LHR-1 engine with crude jatropha oil (CJO) operation at 27° bTDC and at an injector opening pressure of 190bar

This was due to lower calorific value and higher viscosity of the vegetable oil provided a possible explanation for the deterioration in the performance of the engine with vegetable oil operation. This was also because of lower heat release rate of vegetable oil due to its larger droplet mean diameter.

Preheating of the vegetable oil reduced the viscosity, which improved the spray characteristics of the vegetable oil and reduced the impingement of the fuel spray on combustion chamber walls, causing efficient combustion thus improving brake thermal efficiency. Engine with LHR-1 combustion chamber consisted of air gap insulated piston with superni crown and air gap insulated liner with superni insert showed the improvement in the performance at all loads compared with conventional engine with pure diesel operation. High cylinder temperatures helped in better evaporation and improved combustion of the fuel injected into the combustion chamber. Reduction of ignition delay of the vegetable oil in the hot environment of the engine with LHR-1 combustion chamber improved heat release rates and efficient energy utilization. Preheating of vegetable oil improved performance further in LHR-1 version of the combustion chamber.

The variation of parameters with BMEP is small at low loads and hence bar charts are drawn at full load operation at recommended injection timing at an injection pressure of 190 bar. Tables are drawn in order to study the effect of injection pressure and fuel operating condition on performance parameters..

Fig.3 presents bar charts showing peak brake thermal efficiency with conventional engine and engine with LHR-1 combustion chamber with neat diesel and crude jatropha oil operation

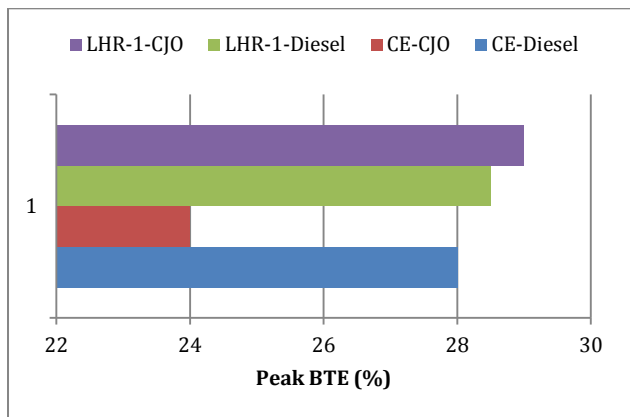

Fig.3 Bar charts showing the variation of peak BTE with conventional engine and LHR-1 engine with neat diesel and crude jatropha oil operation at 27 °bTDC and injection pressure of 190 bar

Conventional engine with vegetable oil operation decreased peak BTE by 14% at recommended injection timing (27° bTDC) when compared with neat diesel operation. This was because of higher viscosity, lower volatility and lower calorific value of the fuel. LHR-1 engine with vegetable oil operation increased peak BTE by 2% at 27° bTDC in comparison with neat diesel operation on same configuration of the engine. LHR-1 engine with vegetable oil operation increased peak BTE by 2% at recommended injection timing when compared with conventional engine with vegetable oil operation. This showed that LHR-1 was more suitable for low calorific value vegetable oil with its improved combustion due to its high heat release rate. This showed that LHR-1 engine was more suitable for vegetable oil operation. Peak BTE was observed to be lower with conventional engine at its recommended injection timing with vegetable oil operation.

Fig.4. presents bar charts showing variation of brake specific energy consumption (BSEC) at full load with conventional engine and LHR-1 engine with neat diesel fuel and crude jatropha oil operation. Brake specific fuel consumption (BSFC) is not used to compare the two different fuels, because their calorific value, density, chemical and physical parameters are different. Performance parameter, BSEC, is used to compare two different fuels as it is defined as energy consumed by the engine in producing unit brake power. Higher the performance of the engine will be observed with lower value of BSEC. From Fig.5, it is evident that conventional engine with crude jatropha oil increased BSEC at full load by 24% at 27° bTDC in comparison with neat diesel operation. This was due to lower calorific value of vegetable oil in comparison with diesel operation. LHR-1 engine with vegetable oil operation decreased BSEC at full load operation by 4% at 27° bTDC when compared with neat diesel operation on same configuration of the engine. Though calorific value of vegetable oil was lower, its density was higher than diesel giving rise to comparable heat input to the engine. This showed that combustion improved with

hot environment provided by LHR-1 engine with vegetable oil operation. LHR-1 engine with vegetable oil operation showed comparable BSEC at full load by 4% at recommended injection timing when compared with neat diesel operation on conventional engine.

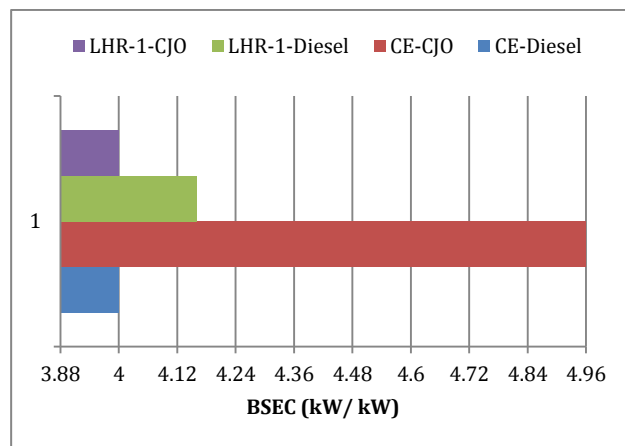

Fig.4 Bar charts showing the variation of brake specific energy consumption (BSEC) with conventional engine and LHR-1 engine with neat diesel and crude jatropha oil operation at 27° bTDC and injection pressure of 190 bar

BSEC at full load was observed to be higher with conventional engine at its recommended injection timing with vegetable oil operation. Experiments were conducted on preheated vegetable oils in order to equalize their viscosity to that of mineral diesel may ease the problems of injection process. Increased injector opening pressure may also result in efficient combustion in compression ignition engine. It has a significant effect on performance and formation of pollutants inside the direct injection diesel engine combustion. By controlling the injector opening pressure and the injection rate, the spray cone angle is found to depend on injection pressure. Further increasing the injector opening pressure increases the nominal mean spray velocity resulting in better fuel-air mixing in the combustion chamber. Higher fuel injection pressures increase the degree of atomization. Performance of the engine is evaluated with varying injection pressure from 190 to 270 bar for conventional and LHR engines.

Table.3 shows data of peak brake thermal efficiency (BTE) and brake specific energy consumption (BSEC) at full load with conventional engine and engine with LHR-1 combustion chamber at recommended injection timing with varied injector opening pressure with different operating conditions of the vegetable oil. Neat diesel operation was also shown for the purpose of comparison. As it is observed from Table.3. peak brake thermal efficiency increased with increase in injector opening pressure at different operating conditions of the vegetable oil. For the same physical properties, as injector opening pressure increased, droplet diameter decreased influencing the

Table.3 Data of peak brake thermal efficiency (BTE) and brake specific energy consumption (BSEC) at full load

Injection timing (° bTDC)	Test Fuel	Peak BTE (%)						Brake Specific Energy Consumption at Full load operation (kW/kW)					
		Injector Opening Pressure (bar)						Injector Opening Pressure (bar)					
		190		230		270		190		230		270	
		NT	PT	NT	PT	NT	PT	NT	PT	NT	PT	NT	PT
27(CE)	DF	28	--	29	---	30	--	4.0	--	3.96	--	3.92	--
	CJO	24	25	25	26	26	27	4.96	4.70	4.70	4.65	4.65	4.60
27(LHR-1)	DF	28.5	---	29	---	29.5	---	4.16	--	4.12	--	4.08	--
	CJO	29	30	30	30.5	30.5	31	4.0	3.96	3.96	3.92	3.92	3.88

atomization quality, and more dispersion of fuel particle, resulting in turn in better vaporization, leads to improved air-fuel mixing rate, as extensively reported in the literature [I.Celikten, 2003; Y.Cingur et al, 2003; D.T. Hountalas et al, 2003; S.Jindal et al, 2010; Avinash Kumar et al, 2013]. In addition, better combustion leads to less fuel consumption. The performance improved further with the preheated vegetable oil when compared with normal vegetable oil.

Preheating of the vegetable oil reduced the viscosity, which improved the spray characteristics of the oil causing efficient combustion thus improving brake thermal efficiency. The cumulative heat release was more for preheated vegetable oil than that of normal vegetable oil and this indicated that there was a significant increase of combustion in diffusion mode. This increase in heat release was mainly due to better mixing and evaporation of preheated vegetable oil, which leads to complete burning. Similar trends were noticed by earlier researchers. [M.V.S.Murali Krishna et al, 2012; Ch.Kesava Reddy et al, 2012; D.Srikanth et al, 2013]. From the Table.3, it is noticed that brake specific energy consumption at full load operation decreased with increase of injector opening pressure with different operating conditions of the test fuels. This was due to reduction of size of fuel particle in fuel spray giving lower brake specific energy consumption. Similar trends were noticed by earlier researchers. [[M.V.S.Murali Krishna et al, 2012; Ch.Kesava Reddy et al, 2012; D.Srikanth et al, 2013]. Brake specific energy consumption at full load decreased with the preheated vegetable oil at full load operation when compared with normal vegetable oil. Preheating of the vegetable oil reduced the viscosity, which improved the spray characteristics of the oil and thus improved combustion leading to decrease BSEC at full load.

Fig.5 presents bar charts showing the variation of exhaust gas temperature at full load operation with test fuels at recommended injection timing and injection pressure of 190 bar. Conventional engine with vegetable oil operation drastically increased exhaust gas temperature at full load in comparison with diesel operation.

Conventional engine increased exhaust gas temperature by 13% at 27° bTDC when compared with neat diesel operation. This was due to higher combustion duration coupled with retarded heat release rate of vegetable oil due to its higher viscosity.

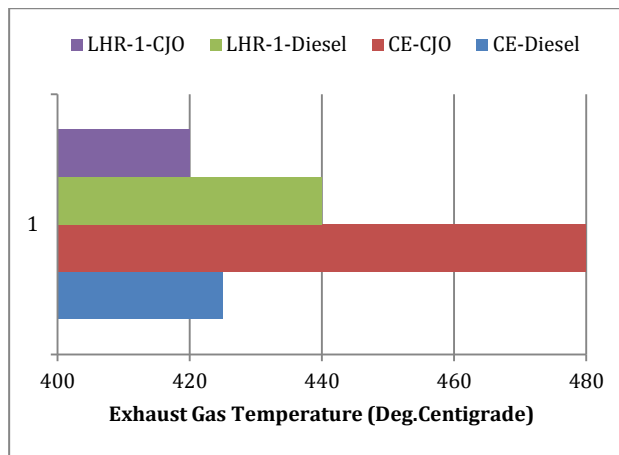

Fig.5. Bar charts showing the variation of exhaust gas temperature with conventional engine and LHR-1 engine with neat diesel and crude jatropha oil operation at 27° bTDC and injection pressure of 190 bar

LHR-1engine with vegetable oil decreased exhaust gas temperature at full load by 5% at 27° bTDC with diesel operation on same configuration of the engine. This was due to reduction of ignition delay with neat diesel operation with high cetane number. This was also because of improved thermal efficiency with LHR-1 engine with vegetable oil operation leading to cause lower heat rejection in comparison with neat diesel operation. LHR-1 engine with vegetable oil operation reduced exhaust gas temperature by 3% at recommended injection timing in comparison with conventional engine with vegetable oil operation. This was due to more conversion of exhaust enthalpy into useful work by LHR-1 engine.LHR-1 engine with vegetable oil operation showed comparable exhaust gas temperature at full load by 8% at recommended injection timing with neat diesel operation on conventional engine. This indicated that heat rejection was restricted with provision of insulation thus maintaining the hot combustion chamber as result of which EGT increased. EGT at full load was observed to be higher with conventional engine at its recommended injection timing with vegetable oil operation.

Fig.6. presents bar charts showing the variation of coolant load at full load operation with test fuels at recommended injection timing at an injector opening pressure of 190 bar.

Table.4. Data of Exhaust Gas Temperature (EGT) and Coolant Load at full load operation

Injection Timing (bTDC)	Test Fuel	EGT at full load operation (degree centigrade)						Coolant load at full load operation (kW)					
		Injector Opening Pressure (bar)						Injector Opening Pressure (bar)					
		190		230		270		190		230		270	
		NT	PT	NT	PT	NT	PT	NT	PT	NT	PT	NT	PT
27(CE)	DF	425	--	410	---	395	--	4.0	---	4.2	--	4.4	---
	CJO	480	500	460	480	440	460	4.3	4.0	4.6	4.5	4.8	4.5
27(LHR-1)	DF	440	---	420	---	400	----	3.9	---	3.7	---	3.5	---
	CJO	420	400	400	380	380	360	3.6	3.4	3.4	3.2	3.2	3.0

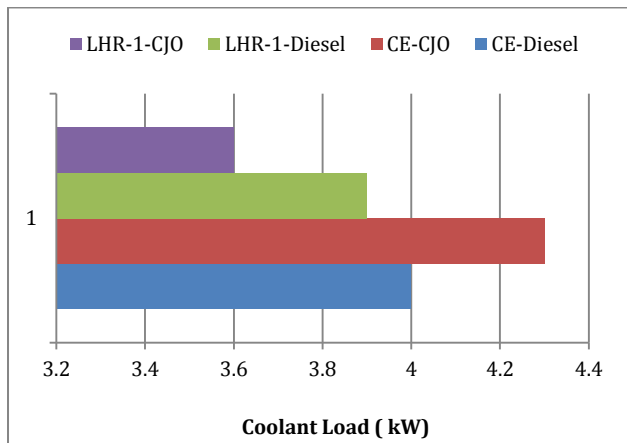

Fig.6 Bar charts showing the variation of coolant load with conventional engine and LHR-1 engine with neat diesel and crude jatropha oil operation at 27° bTDC and injection pressure of 190 bar

Conventional engine with vegetable oil operation increased coolant load at full load in comparison with diesel operation. Conventional engine increased coolant load at full load by 8% at 27° bTDC when compared with neat diesel operation. This was due to increase of exhaust gas temperature and concentration of un-fuel at combustion chamber walls with vegetable oil operation. LHR-1 engine with vegetable oil decreased coolant load at full load by 15% at 27° bTDC in comparison with diesel operation on same configuration of the engine. This was due to increase of exhaust gas temperatures with diesel operation on LHR-1 engine. This was also because of higher thermal efficiency with LHR-1 engine with vegetable oil operation leading to cause lower amount of heat rejection.

LHR-1 engine with vegetable oil operation reduced coolant load by 16% at recommended injection timing when compared with conventional engine with vegetable oil operation. This was due to provision of thermal insulation with LHR-1 engine and reduction of gas temperatures causing reduction of heat loss to the coolant. Similar trends were noticed by earlier researchers [M.V.S.Murali Krishna et al, 2012; Ch.Kesava Reddy et al, 2012; D.Srikanth et al, 2013]. LHR-1 engine with vegetable oil operation reduced coolant load at full load by 10% at recommended injection timing when compared with neat diesel

operation on conventional engine. This showed that there was less amount of heat rejection in form of coolant load with LHR-1 engine with vegetable oil operation and more amount of heat was utilized in form of actual work.

Table.4 shows data of exhaust gas temperature at full load and coolant load at full load at full load with conventional engine and engine with LHR-1 combustion chamber at recommended injection timing with varied injector opening pressure with different operating conditions of the vegetable oil. Neat diesel operation was also shown for the purpose of comparison. Exhaust gas temperatures decreased with increase in injector opening pressure with test fuels as it is evident from the Table.4. This was due to improved oxygen-fuel ratios and spray characteristics of the fuel with increase of injector opening pressure. From Table.4, it is noticed that the exhaust gas temperatures of preheated vegetable oil were higher than that of normal vegetable oil in conventional engine, which indicates the increase of diffused combustion due to high rate of evaporation and improved mixing between vegetable oil and air. Therefore, as the fuel temperature increased, the ignition delay decreased and the main combustion phase (that is, diffusion controlled combustion) increased, which in turn raised the temperature of exhaust gases. However, marginal reduction of exhaust gas temperature was observed with LHR-1 engine with preheated vegetable oil. This was due to improved air fuel ratios with LHR-1engine. Similar trends were observed by earlier researchers.

From Table.4, it is seen that coolant load increased marginally in the conventional engine while it decreased in the engine with LHR-1 combustion chamber with increasing of the injector opening pressure with test fuels. This was due to the fact with increase of injector opening pressure with conventional engine, increased nominal fuel spray velocity resulting in better fuel-air mixing with which gas temperatures increased. The reduction of coolant load in the engine with LHR-1 combustion chamber was not only due to the provision of the insulation but also it was due to better fuel spray characteristics and increase of oxygen-fuel ratios causing decrease of gas temperatures and hence the coolant load. Coolant load decreased marginally with preheated vegetable oil in comparison with normal vegetable oil. This was due to

improved air fuel ratios with improved spray characteristics. Similar trends were noticed by earlier researchers [M.V.S.Murali Krishna et al, 2012; Ch.Kesava Reddy et al, 2012; D.Srikanth et al, 2013]

The performance of the engine is judged by its sound. Sound levels increased with increase of brake mean effective pressure with both version of the combustion chamber with test fuels at an injector opening pressure of 190 bar (Fig not shown). This was due to higher fuel consumption and heterogeneous combustion of air fuel mixture in diesel engine. However, sound levels decreased marginally at 80% of the full load due to efficient combustion with improved air fuel ratios and again sound levels increased drastically and attained maximum value at full load operation of the both versions of the engine. Vegetable oil operation at recommended injection timing showed higher sound levels with conventional engine as combustion deteriorated with vegetable oil operation. Fig.7 presents bar charts showing the variation of sound levels at full load operation with test fuels at recommended injection timing at an injector opening pressure of 190 bar.

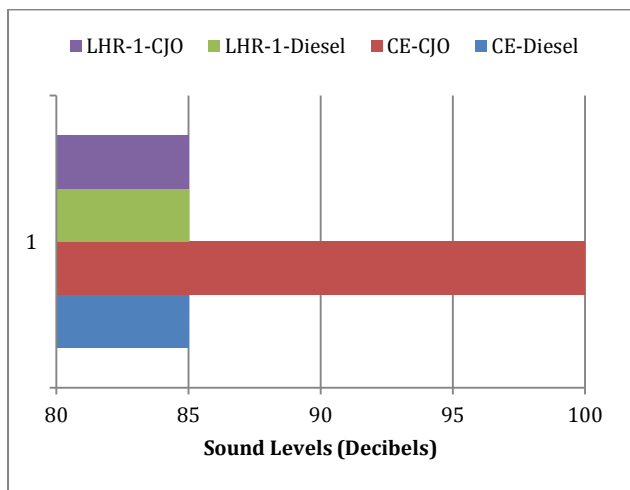

Fig.7 Bar charts showing the variation of sound levels with conventional engine and LHR-1 engine with neat diesel and crude jatropha oil operation at 27° bTDC and injection pressure of 190 bar

Conventional engine with vegetable oil operation increased sound levels at full load in comparison with diesel operation. Conventional engine increased sound levels at full load by 14% at 27° bTDC when compared with neat diesel operation. This was due to deterioration of combustion of vegetable oil operation with conventional engine. LHR-1 engine with vegetable oil showed comparable sound levels at full load at 27° bTDC in comparison with diesel operation on same configuration of the engine, which confirmed that LHR-1 engine showed improved performance with vegetable oil operation in comparison with diesel operation. LHR-1 engine with vegetable oil operation reduced sound levels by 15% at recommended injection timing when compared with conventional

engine with vegetable oil operation, which showed that combustion improved with LHR-1 engine with vegetable oil operation in comparison with conventional engine. LHR-1 engine with vegetable oil operation reduced sound levels at full load by 5% at recommended injection timing when compared with neat diesel operation on conventional engine. This was due to provision of insulation with air gap with LHR-1 engine. Sound levels at full load were observed to be higher with conventional engine at recommended injection timing with vegetable oil operation.

Volumetric efficiency depends on density of the charge which intern depends on temperature of combustion chamber wall. Fig.8 presents bar charts showing the variation of volumetric efficiency at full load operation with test fuels at recommended injection timing at an injector opening pressure of 190 bar.

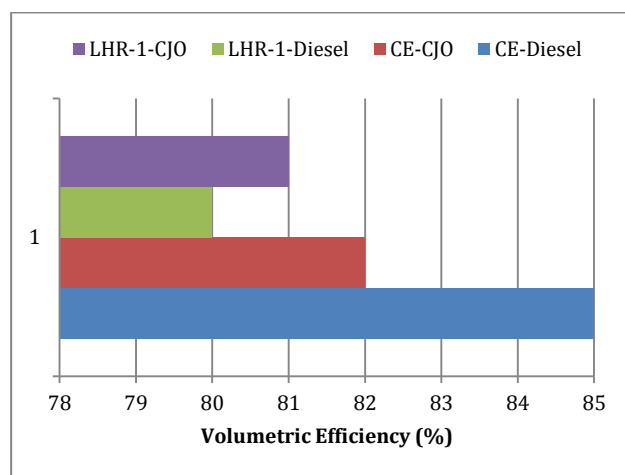

Fig. 8 Bar charts showing the variation of volumetric efficiency with conventional engine and LHR-1 engine with neat diesel and crude jatropha oil operation at 27° bTDC and injection pressure of 190 bar

Conventional engine with vegetable oil operation decreased volumetric efficiency at full load in comparison with diesel operation. Conventional engine decreased volumetric efficiency at full load by 4% at 27° bTDC when compared with neat diesel operation. This was due to decrease of air fuel ratios and increase of exhaust gas temperature at full load with vegetable oil operation with conventional engine. LHR-1 engine with vegetable oil showed comparable volumetric efficiency at full load at 27° bTDC in comparison with diesel operation on same configuration of the engine. LHR-1 engine with vegetable oil operation reduced volumetric efficiency at full load by 3% at recommended injection timing in comparison with conventional engine with vegetable oil operation. This was because of heating of the charge with hot insulated components of LHR-1 combustion chamber with which density of the charge decreased and hence mass of air inducted decreased. LHR-1 engine with vegetable oil operation reduced volumetric efficiency at full load by

Table.5 Data of Sound Levels at full load and Volumetric Efficiency at full load with test fuels at full load operation

Injection timing (bTDC)	Test fuels	Sound Levels at full load operation (Decibels)						Volumetric Efficiency (%) at full load operation					
		Injector Opening Pressure (Bar)						Injector Opening Pressure (Bar)					
		190		230		270		190		230		270	
		NT	PT	NT	PT	NT	PT	NT	PT	NT	PT	NT	PT
27(CE)	DF	85	--	80	--	75	--	85	--	86	--	87	--
	CJO	100	90	90	85	85	80	82	81	83	82	84	83
27(LHR-1)	DF	85	---	80	---	75	---	80	---	81	---	82	---
	CJO	85	80	80	75	75	70	81	82	82	83	83	84

6% at recommended injection timing when compared with neat diesel operation on conventional engine. As mentioned earlier, this was because of heating of charge with hot insulated components of LHR-1 engine. Volumetric efficiency at full load was observed to be lower with LHR-1 engine at recommended injection timing with vegetable oil operation.

Table.5 shows data of sound levels at full load and volumetric efficiency at full load at full load with conventional engine and engine with LHR-1 combustion chamber at recommended injection timing with varied injector opening pressure with different operating conditions of the vegetable oil. Neat diesel operation was also shown for the purpose of comparison. Table 5 denotes that the sound levels decreased with increase of injector opening pressure with the test fuels. This was due to improved spray characteristic of the fuel, with which there was no impingement of the fuel on the walls of the combustion chamber leading to produce efficient combustion. Sound levels were lower at preheated condition of preheated vegetable oil when compared with their normal condition. This was due to improved spray characteristics, decrease of density and viscosity of the fuel.

From Table-5, it is evident that volumetric efficiency increased with increase of injector opening pressure with test fuels. This was due to improved fuel spray characteristics and evaporation at higher injection pressures leading to marginal increase of volumetric efficiency. This was also because of decrease of exhaust gas temperatures and hence combustion chamber wall temperatures. This was also due to the reduction of residual fraction of the fuel, with the increase of injector opening pressure. Similar trends were expressed by earlier studies [M.V.S.Murali Krishna et al, 2012; Ch.Kesava Reddy et al, 2012; D.Srikanth et al, 2013]Preheating of the vegetable oil marginally decreased volumetric efficiency, when compared with the normal temperature of vegetable oil with conventional engine, because of reduction of bulk modulus, density of the fuel and increase of exhaust gas temperatures. However, volumetric efficiency was observed to be increased marginally with LHR-1 engine with preheated vegetable oil due to reduction of exhaust gas temperature at full load with improved air fuel ratios.

Conclusions

1. Engine with LHR-1 combustion chamber consisted of ceramic coated cylinder head with vegetable oil operation showed improved performance in terms of brake thermal efficiency, exhaust gas temperature, coolant load, volumetric efficiency, and sound levels at 27 °bTDC in comparison with conventional engine with vegetable oil operation at 27 °bTDC.
2. Engine with LHR-1 combustion chamber with vegetable oil operation showed improved performance at 27 ° bTDC in comparison with conventional engine with diesel operation at 27 ° bTDC.
3. Engine with LHR-1 combustion chamber with vegetable oil operation showed improved at 27 ° bTDC in comparison with same configuration of the engine with diesel operation
4. Performance parameters improved marginally with an increase of injector opening pressure with vegetable oil operation with both versions of the combustion chamber.

Research Findings

Comparative studies on performance parameters with direct injection diesel engine with LHR-1 combustion chamber and conventional combustion chamber were made at varied injection pressure with neat vegetable oil operation.

Future Scope of Work

Studies on exhaust emissions with varied injection timing and injection pressure with vegetable oil operation on engine with LHR-1 combustion chamber can be taken up.

Acknowledgments

Authors thank authorities of Chaitanya Bharathi Institute of Technology, Hyderabad for providing facilities for carrying out this research work. Financial assistance provided by All India Council for Technical Education (AICTE), New Delhi, is greatly acknowledged.

References

- Avinash Kumar Agarwal and Atul Dha.(2009), Performance, emission and combustion characteristics of jatropha oil blends in a direct injection CI engine, SAE Paper 2009-01-0947.
- Misra, R.D, and Murthy, M.S. (2010), Straight vegetable oils usage in a compression ignition engine—A review, *Renew Sustain Energy Rev*, 14, pp. 3005–3013.
- Soo-Young, No. (2011), Inedible vegetable oils and their derivatives for alternative diesel fuels in CI engines: A review, *Renew Sustain Energy Rev*, 15, pp. 131–149.
- Avinash Kumar Agarwal and Atul Dhar. (2013), Experimental investigations of performance, emission and combustion characteristics of Karanja oil blends fuelled DIC engine, *Renewable Energy*, 52, pp. 283–291
- Venkateswara Rao, N., Murali Krishna, M.V.S., and Murthy,P.V.K. (2013), comparative studies on exhaust emissions and combustion characteristics of tobacco seed oil in crude form and biodiesel form in direct injection diesel engine. *International Journal of Mechanical and Production Engineering Research and Development*, 3(4), pp.25-138.
- Srikanth, D., Murali Krishna M.V.S., Ushasri, P., et al. (2013), Performance evaluation of a diesel engine fuelled with cotton seed oil in crude form and biodiesel form, *Int J Acad Res Multidiscip*, 1 (9), pp. 329–349.
- Krishna, Maddali, and Chowdary, R. (2014), Comparative studies on performance evaluation of waste fried vegetable oil in crude form and biodiesel form in conventional diesel engine, SAE Paper 2014-01-1947, 2014.
- Prasada Rao, D., Murali Krishna., M.V.S., Anjeneya Prasad, B. (2014), Effect of injector opening pressure and injection timing on exhaust emissions and combustion characteristics of rice bran oil in crude form and biodiesel form in direct injection diesel engine, *IOSR J Eng* 4(2), pp.9–19.
- Celikten, I.(2003), An experimental investigation of the effect of the injection pressure on the engine performance and exhaust emission in indirect injection diesel engines. *Applied Thermal Engineering*, 23, pp.2051–2060.
- Cingur, Y., and Altiparmak, D.(2003), Effect of cetane number and injection pressure on a DI diesel engine performance and emissions. *Energy Conversion and Management*, 44, pp. 389–397.
- Hountalas, D.T., Kouremenos, D.A., Binder, K.B., Schwarz, V., & Mavropoulos, G.C. (2003), Effect of injection pressure on the performance and exhaust emissions of a heavy duty DI diesel engine, *SAE Technical Paper No. 2003-01-0340*. Warrendale, PA
- Jindal, S., Nandwana, B.P., Rathore, N.S. and Vashistha,V.. (2010), Experimental investigation of the effect of compression ratio and injector opening pressure in a direct injection diesel engine running on Jatropha methyl ester, *Applied Thermal Engineering*, 30,442–448.
- Avinash Kumar Agarwal, Dhananjay Kumar Srivastava, Atul Dhar, et al. (2013), Effect of fuel injection timing and pressure on combustion, emissions and performance characteristics of a single cylinder diesel engine, *Fuel*, 111, pp. 374–83.
- Parlak, A., Yasar, H., Idogan O. (2005).The effect of thermal barrier coating on a turbocharged Diesel engine performance and exergy potential of the exhaust gas. *Energy Conversion and Management*, 46(3), pp.489–499.
- Ekrem, B., Tahsin, E., Muhammet, C. (2006). Effects of thermal barrier coating on gas emissions and performance of a LHR engine with different injection timings and valve adjustments. *Journal of Energy Conversion and Management*, 47,pp.1298-1310.
- Ciniviz, M., Hasimoglu, C., Sahin, F., Salman, M. S. (2008). Impact of thermal barrier coating application on the performance and emissions of a turbocharged diesel engine. *Proceedings of The Institution of Mechanical Engineers Part D-Journal Of Automobile Eng*,222 (D12), ISSN: : 0954-4070, 2447–2455.
- Murali Krishna, M.V.S., Janardhan, N., Kesava Reddy,Ch., and Krishna Murthy,P.V. (2014), Experimental investigations on DI diesel engine with different combustion chambers, *British Journal of Applied Science & Technology*, 6(3), pp.239–260.
- Murali Krishna, M.V.S., Chowdary, R.P., Reddy, T.K.K. and Murthy,P.V.K.. (2012). Performance evaluation of waste fried vegetable oil in la low grade low heat rejection diesel engine. *International Journal of Research in Mechanical Engineering and Technology*, 2(2), pp.35-43.
- Kesava Reddy, Ch., Murali Krishna, M.V.S., Murthy, P.V.K., and Ratna Reddy,T. (2012).Performance evaluation of a low grade low heat rejection diesel engine with crude Pongamia oil. *International Scholarly Research Network (ISRN) Renewable Energy Article ID 489605*, 1-10.
- D.Srikanth, M.V.S. Murali Krishna, P.Ushasri and P.V.Krishna Murthy. (2013). Performance parameters of ceramic coated diesel engine fuelled with cotton seed oil in crude form and biodiesel form, *International Journal of Automobile Engineering and Research Development*, 3(4), pp35-44.
- M.V.S.Murali Krishna, (2004), Performane evaluation of LHR diesel engine with alternative fuels, PhD Thesis, JNT University, Hyderabad,India