

## Research Article

## Studies on Exhaust Emissions from Two Stroke Copper Coated Spark Ignition Engine with Alcohol Blended Gasoline with Catalytic Converter

S. Narasimha Kumar<sup>Å\*</sup><sup>Å</sup>Department of Mechanical Engineering, Chaitanya Bharathi Institute of Technology, Gandipet, Hyderabad-500075Accepted 10 January 2014, Available online 01 February 2014, **Special Issue-2, (February 2014)**

### Abstract

Experiments were conducted to control the exhaust emissions from two-stroke, single cylinder, spark ignition (SI) engine, with alcohol blended gasoline (90% gasoline, 10% ethanol by volume) having copper coated combustion chamber [CCCC, copper-(thickness, 300  $\mu$ ) coated on piston crown, inner side of cylinder head] provided with catalytic converter with sponge iron as catalyst and compared with conventional SI engine (CE) with pure gasoline operation. Aldehydes were measured by wet chemical method. Exhaust emissions of CO and UBHC were evaluated at different values of brake effective pressure, while aldehydes were measured at full load operation of the engine. A microprocessor-based analyzer was used for the measurement of CO/UBHC in the exhaust of the engine. Copper coated combustion chamber with alcohol blended gasoline considerably reduced pollutants in comparison with CE with pure gasoline operation. Catalytic converter with air injection significantly reduced pollutants with test fuels on both configurations of the engine. The catalyst, sponge reduced the pollutants effectively with both test fuels in both versions of the engine.

**Keywords:** S.I. Engine, CE, copper coated combustion chamber, Exhaust Emissions, CO, UBHC, aldehydes, Catalytic converter, Sponge iron, Air injection

### 1. Introduction

The paper is divided into i) Introduction, ii) Materials and Methods, iii) Results and Discussions, iv) Conclusions, Research Findings, Future scope of work followed by References.

This section deals with exhaust emissions from SI engine, their formation, effect of pollutants on human health, their impact on environment, change of fuel composition to reduce pollutants, engine modification to improve the performance and reduce pollutants, methods of reducing pollutants, catalytic converter, research gaps, objective of the experimentation.

Carbon monoxide (CO) and un-burnt hydrocarbons (UBHC), major exhaust pollutants formed due to incomplete combustion of fuel, cause many human health disorders. These pollutants cause asthma, bronchitis, emphysema, slowing down of reflexes, vomiting sensation, dizziness, drowsiness, etc. Such pollutants also cause detrimental effects on animal and plant life, besides environmental disorders. Age and maintenance of the vehicle are some of the reasons for the formation of pollutants. Aldehydes which are intermediate compound formed in combustion, are carcinogenic in nature and cause detrimental effects on human health and hence control of these pollutants is an immediate task.

Engine modification with copper coating on piston crown and inner side of cylinder head improves engine

performance as copper is a good conductor of heat and combustion is improved with copper coating. The use of catalysts to promote combustion is an old concept. More recently copper is coated over piston crown and inside of cylinder head wall and it is reported that the catalyst improved the fuel economy and increased combustion stabilization.

Catalytic converter is one of the effective methods to reduce pollutants in SI engine. Reduction of pollutants depended on mass of the catalyst, void ratio, temperature of the catalyst, amount of air injected in the catalytic chamber. A reduction of 40% was reported with use of sponge iron catalyst while with air injection in the catalytic chamber reduced pollutants by 60%.

Alcohol was blended with gasoline to reduce pollutants. CO and UBHC emissions reduced with blends of alcohol with gasoline.

The present paper reported the control of exhaust emissions of CO, UBHC and aldehydes (formaldehydes and acetaldehydes) from two stroke SI engine with alcohol blended gasoline in different configurations of the combustion chamber with catalytic converter with sponge iron as catalyst and compared with gasoline operation on CE.

### 2. Materials and Methods

This section deals with fabrication of copper coated combustion chamber, description of experimental set up,

\*Corresponding author: S. Narasimha Kumar

operating conditions of catalytic converter and method of measuring aldehydes and definition of used values

In catalytic coated combustion chamber, crown of the piston and inner surface of cylinder head are coated with copper by flame spray gun. The surface of the components to be coated are cleaned and subjected to sand blasting. A bond coating of nickel- cobalt- chromium of thickness 100 microns is sprayed over which copper (89.5%), aluminium (9.5%) and iron (1%) alloy of thickness 300 microns is coated with METCO flame spray gun. The coating has very high bond strength and does not wear off even after 50 h of operation.

Figure.1. shows experimental set-up used for investigations. A two- stroke, single-cylinder, air -cooled, SI engine (brake power 2.2 kW at a speed of 3000 rpm) was coupled to a rope brake dynamometer for measuring its brake power. Speed was measured with speed sensor and torque with torque sensor. Compression ratio of engine is 7.5:1. Exhaust gas temperature, speed, torque, fuel consumption and air flow rate of the engine were measured with electronic sensors. The diameter and stroke of the cylinder were 57 mm each. Recommended spark ignition timing was 25°aTDC. CO and UBHC emissions in engine exhaust were measured with Netel Chromatograph analyzer.

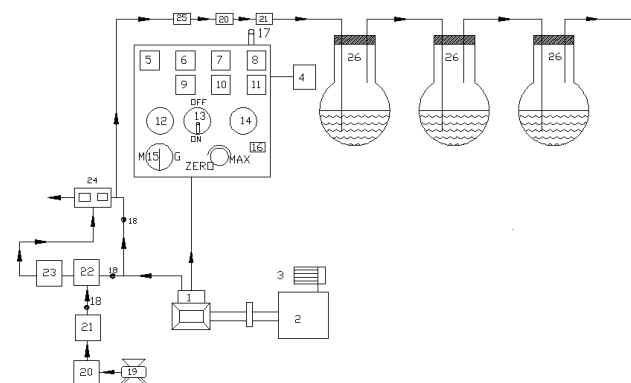

1. Engine, 2.Electrical swinging field dynamometer, 3. Loading arrangement, 4.Fuel tank, 5.Torque indicator/controller sensor, 6. Fuel rate indicator sensor, 7. Hot wire gas flow indicator, 8. Multi channel temperature indicator, 9. Speed indicator, 10. Air flow indicator, 11. Exhaust gas temperature indicator, 12. Mains ON, 13. Engine ON/OFF switch, 14. Mains OFF, 15. Motor/Generator option switch, 16. Heater controller, 17. Speed indicator, 18. Directional valve, 19. Air compressor, 20. Rotometer, 21. Heater, 22. Air chamber, 23. Catalytic chamber, 24. CO/HC analyzer, 25. Filter, 26. Round bottom flasks containing DNPH solution,

**Fig.1** Schematic Diagram of Experimental set up

A catalytic converter (Figure.2) is fitted to exhaust pipe of engine. Provision is also made to inject a definite quantity of air into catalytic converter. Air quantity drawn from compressor and injected into converter is kept constant so that backpressure does not increase. Experiments are carried out on CE and copper coated combustion chamber with different test fuels [pure gasoline and alcohol blended gasoline (10% by vol)] under different operating conditions of catalytic converter like set-A, without catalytic converter and without air injection; set-B, with catalytic converter and without air injection; and set-C,

with catalytic converter and with air injection. Air fuel ratio is varied so as to obtain different equivalence ratios.

For measuring aldehydes in the exhaust of the engine, a wet chemical method is employed. The exhaust of the engine is bubbled through 2,4-dinitrophenyl hydrazine (DNPH) in hydrochloric acid solution and the hydrazones formed from aldehydes are extracted into chloroform and are analyzed by high performance liquid chromatography (HPLC) to find the percentage concentration of formaldehyde and acetaldehyde in the exhaust of the engine.

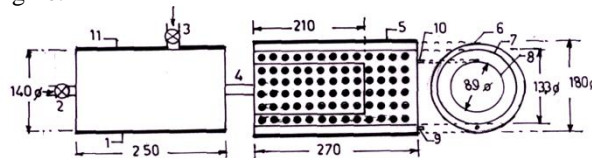

1.Air chamber, 2.Inlet for air chamber from the engine, 3.Inlet for air chamber from compressor, 4.Outlet for air chamber, 5.Catalyst chamber, 6. Outer cylinder, 7. Intermediate cylinder, 8.Inner cylinder, 9. Outlet for exhaust gases, 10.Provision to deposit the catalyst and 11.Insulation

**Fig.2.** Details of Catalytic converter

Definitions of used values:

Brake mean effective pressure: It is defined as specific torque of the engine. Its unit is bar.

$$BP = \frac{BMEP \times 10^5 \times L \times A \times n \times k}{60000}$$

BP =Brake power of the engine in kW;

BMEP= Brake mean effective pressure of the engine in bar

L= Stroke of the piston in m

A= Area of the piston =  $\frac{3.14 \times D^2}{4}$ , Where D= Bore of the cylinder in m

n= Effective number of power cycles =  $\frac{N}{2}$ , where N=Speed of the engine = 3000 rpm

### 3. Results and Discussion

This section deals with variation of CO emissions and UBHC emissions with brake mean effective pressure (BMEP) of the engine, variation of CO emissions and UBHC emissions with equivalence ratio and control of these pollutions along with aldehydes with different operating conditions of the catalytic converter.

Figure.3 shows the variation of CO emissions with BMEP in different versions of the engine with both pure gasoline and alcohol blended gasoline. CO emissions decreased with alcohol blended gasoline at all loads when compared to pure gasoline operation on copper coated combustion chamber and CE, as fuel-cracking reactions were eliminated with alcohol.. The combustion of methanol or ethanol produces more water vapor than free carbon atoms as methanol has lower C/H ratio of 0.25, while with ethanol 0.33, against 0.50 of gasoline. Methanol or ethanol has oxygen in its structure and hence its blends have lower stoichiometric air requirements compared to gasoline. Therefore more oxygen that is available for combustion with the blends of methanol and

gasoline, leads to reduction of CO emissions. Methanol or ethanol dissociates in the combustion chamber of the engine forming hydrogen, which helps the fuel-air mixture to burn quickly and thus increases combustion velocity, which brings about complete combustion of carbon present in the fuel to CO<sub>2</sub> and also CO to CO<sub>2</sub> thus makes leaner mixture more combustible, causing reduction of CO emissions.

Copper coated combustion chamber reduced CO emissions in comparison with CE. Copper or its alloys acts as catalyst in combustion chamber, whereby facilitates effective combustion of fuel leading to formation of CO<sub>2</sub> instead of CO. Similar trends were observed with Reference with pure gasoline operation on copper coated combustion chamber.

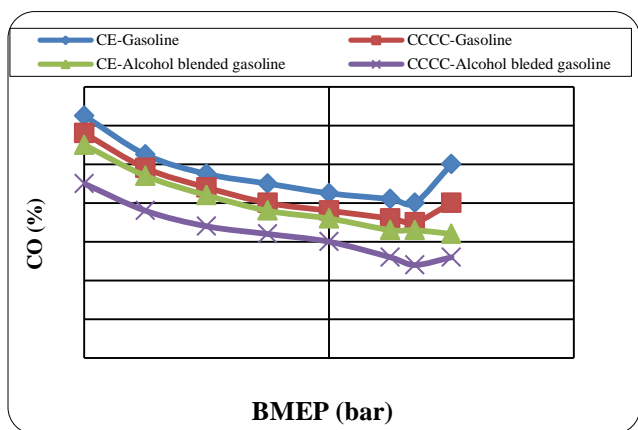

CE- conventional engine:CCCC-Copper coated combustion chamber, CO- Carbon monoxide emissions: BMEP-Brake mean effective pressure

**Figure. 3** Variation of CO emissions with BMEP indifferent versions of the combustion chamber with pure gasoline and alcohol blended gasoline at a compression ratio of 7.5:1 and speed of 3000 rpm

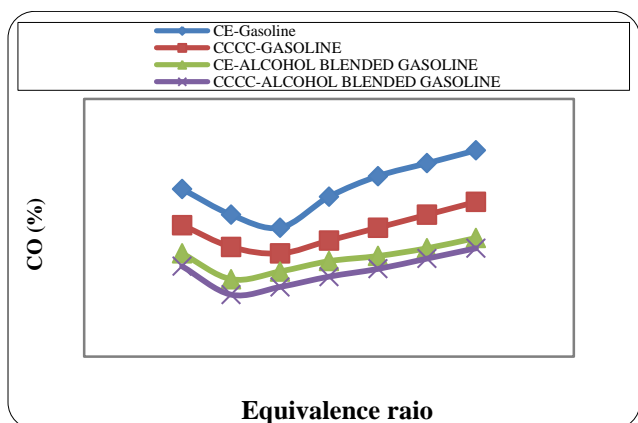

CE- conventional engine: CCCC-Copper coated combustion chamber, CO- Carbon monoxide emissions:

**Figure. 4** Variation of CO emissions with Equivalence ratio in both versions of the combustion chamber with different test fuels with a compression ratio of 7.5:1 at a speed of 3000 rpm

Figure.4 shows the variation of CO emissions with equivalence ratio,  $\phi$  in both configurations of the engine with pure gasoline and alcohol blended gasoline. At leaner mixtures marginal increased CO emissions, and rich mixtures drastically increased CO emissions with both test fuels in different configurations of the combustion chamber. With alcohol blended gasoline operation, minimum CO emissions were observed at  $\phi = 0.85$ , and with pure gasoline operations, minimum CO emissions are observed at  $\phi = 0.9$  with both configurations of the engine. This was due to lower value of stoichiometric air requirement of alcohol blended gasoline when compared with gasoline. Very rich mixtures have incomplete combustion. Some carbon only burns to CO and not to CO<sub>2</sub>.

Table-1 shows the data of CO emissions with different test fuels with different configurations of the combustion chamber at different operating conditions of the catalytic converter with different catalysts. From the table, it can be observed that CO emissions decreased considerably with catalytic operation in set-B with alcohol blended gasoline and further decrease in CO is pronounced with air injection with the same fuel. The effective combustion of the alcohol blended gasoline itself decreased CO emissions in both configurations of the combustion chamber. CO emissions were observed to be higher with alcohol blended gasoline operation in comparison with pure gasoline operation in both versions of the combustion chamber at different operating conditions of the catalytic converter. This is due to the reason that C/H ratio of alcohol blended gasoline is lower in comparison with that of pure gasoline operation.

**Table-1** Data Of ‘Co’ Emissions (%) With Different Test Fuels With Different Configurations Of The Combustion Chamber At Different Operating Conditions Of The Catalytic Converter At Full Load Operation At A Compression Ratio Of 7.5:1 And Speed Of 3000 Rpm.

Set	Conventional Engine (CE)		Copper Coated Combustion Chamber (CCCC)	
	Pure Gasoline	Alcohol blended gasoline	Pure Gasoline	Alcohol blended gasoline
Set-A	5	3.4	4	2.8
Set-B	3	2.2	2.4	1.8
Set-C	2.0	1.5	1.6	1.3

Set-A- Without catalytic converter and without air injection, Set-B: With catalyst and without air injection, Set-C: With catalyst and with air injection

Figure.5 shows the variation of un-burnt hydro carbon emissions (UBHC) with BMEP in different versions of the combustion chamber with both test fuels. UBHC emissions followed the similar trends as CO emissions in copper coated combustion chamber and CE with both test fuels, due to increase of flame speed with catalytic activity and reduction of quenching effect with copper coated combustion chamber.

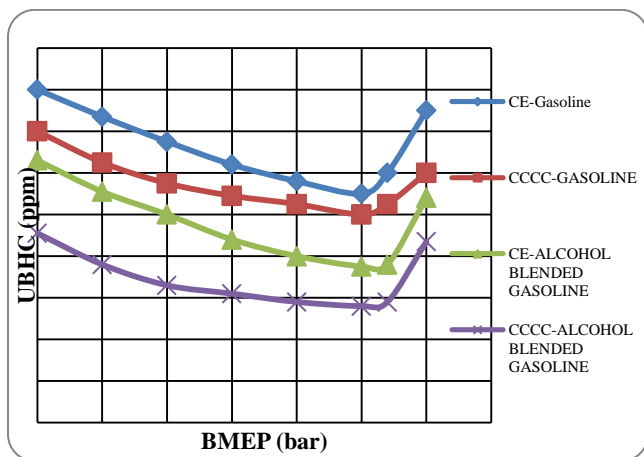

CE-conventionalengine: CCCC-Copper coated combustion chamber, UBHC- Un-burnt hydro carbons: BMEP-Brake mean effective pressure

**Figure. 5** Variation of UBHC emissions with BMEP in different versions of the combustion chamber with pure gasoline and alcohol blended gasoline at a compression ratio of 7.5:1 and speed of 3000 rpm

Figure. 6 shows the variation of UBHC emissions with equivalence ratio,  $\phi$  with pure gasoline and alcohol blended gasoline with both configurations of the combustion chamber. The trends followed by UBHC emissions are similar to those of CO emissions. Drastic increase of UBHC emissions was observed at rich mixtures with both test fuels in different configurations of the combustion chamber. In the rich mixture some of the fuel will not get oxygen and will not burn. During starting from the cold, rich mixture was supplied to the engine, hence marginal increase of UBHC emissions was observed at lower value of equivalence ratio.

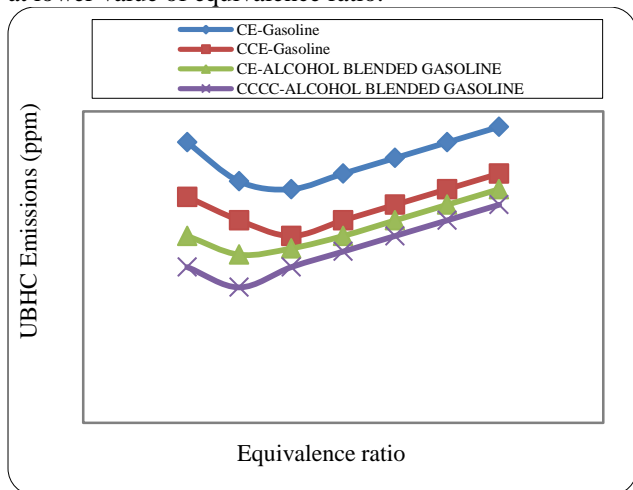

CE- conventional engine: CCCC-Copper coated combustion chamber, UBHC-Un-burnt hydro carbons

**Figure. 6** Variation of UBHC emissions with Equivalence ratio in both versions of the combustion chamber with different test fuels with a compression ratio of 7.5:1 at a speed of 3000 rpm

Table-2 shows the data of UBHC emissions with different test fuels with different configurations of the combustion chamber at different operating conditions of the catalytic converter with sponge iron. The trends observed with UBHC emissions were similar to those of CO emissions in both versions of the combustion chamber with both test fuels.

From Table, it is observed that catalytic converter reduced UBHC emissions considerably with both versions of the combustion chamber and air injection into catalytic converter further reduced pollutants. In presence of catalyst, pollutants further oxidised to give less harmful emissions like CO<sub>2</sub>. Similar trends are observed with Reference with pure gasoline operation on copper coated combustion chamber.

**Table-2** Data of ‘UBHC’ emissions (ppm) with different test fuels with different configurations of the combustion chamber at different operating conditions of the catalytic converter at full load operation at a compression ratio of 7.5:1 and speed of 3000 rpm.

Set	Conventional Engine (CE)		Copper Coated Combustion Chamber (CCCC)	
	Pure Gasoline	Alcohol blended gasoline	Pure Gasoline	Alcohol blended gasoline
Set-A	750	560	600	460
Set-B	450	360	360	290
Set-C	300	245	240	200

Set-A- Without catalytic converter and without air injection, Set-B: With catalyst and without air injection, Set-C: With catalyst and with air injection

The data of formaldehyde and acetaldehyde emissions is listed in Table-3 and Table-4 respectively at full load with different versions of the engine at different operating conditions of the catalytic converter with different test fuels of pure gasoline and alcohol blended gasoline repetitively. The formaldehyde emissions in the exhaust decreased considerably with the use of catalytic converter, which was more pronounced with an air injection into the converter. Alcohol blended gasoline increased formaldehyde emissions considerably due to partial oxidation compared with pure gasoline. The low combustion temperature lead to produce partially oxidized carbonyl (aldehyde) compounds with alcohol blended gasoline. Copper coated combustion chamber decrease formaldehyde emissions when compared with CE.

The trend exhibited by acetaldehyde emissions is same as that of formaldehyde emissions. The partial oxidation of alcohol blended specifically ethanol during combustion predominantly leads to formation of acetaldehyde. Copper (catalyst) coated engine decreased aldehydes emissions considerably by effective oxidation when compared to CE. Catalytic converter with air injection drastically decreased aldehyde emissions in both versions of the combustion chamber due to oxidation of residual aldehydes in the exhaust.

**Table-3** Data of Formaldehyde Emissions (% Concentration) With Different Test Fuels With Different Configurations Of The Combustion Chamber At Different Operating Conditions Of The Catalytic Converter At A Compression Ratio Of 7.5:1 And Speed Of 3000 Rpm

	Conventional Engine (CE)		Copper Coated Combustion Chamber (CCCC)	
	Pure Gasoline	Alcohol blended gasoline	Pure Gasoline	Alcohol blended gasoline
Set-A	9.1	19.8	6.8	12.8
Set-B	6.3	6	9.1	9.8
Set-C	3.5	5	6.5	5.5

Set-A- Without catalytic converter and without air injection, Set-B: With catalyst and without air injection, Set-C: With catalyst and with air injection

**Table-4** Data of Acetaldehyde Emissions (% Concentration) With Different Test Fuels With Different Configurations Of The Combustion Chamber At Different Operating Conditions Of The Catalytic Converter

Set	Conventional Engine (CE)		Copper Coated Combustion Chamber (CCCC)	
	Pure Gasoline	Alcohol blended gasoline	Pure Gasoline	Alcohol blended gasoline
Set-A	7.7	15.8	4.9	13.1
Set-B	4.9	8.9	3.5	8.1
Set-C	2.1	6.9	1.4	5.2

Set-A- Without catalytic converter and without air injection, Set-B: With catalyst and without air injection, Set-C: With catalyst and with air injection

**4. Conclusions**

1. CO and UBHC emissions at full load operation decreased by 20% with CCE when compared with CE with both test fuels.
2. With copper coated combustion chamber, formaldehyde emissions decreased by 25% in comparison with pure gasoline operation on CE
3. With copper coated combustion chamber, formaldehyde emissions decreased by 39% in comparison with alcohol blended gasoline operation on CE
4. With copper coated combustion chamber, acetaldehyde emissions decreased by 36% in comparison with pure gasoline operation on CE
5. With copper coated combustion chamber, acetaldehyde emissions decreased by 21% in comparison with alcohol blended gasoline operation on CE
6. Set-B operation decreased CO, UBHC and aldehyde emissions by 40%, while Set-C operation decreased these emissions by 60% with test fuels when compared with Set-A operation.
7. Sponge iron is proved to be more effective in reducing the pollutants.

**4.1 Research Findings and Future Scope of Work**

Investigations on control of exhaust emissions in two-stroke SI engine were systematically carried out. However, performance of the copper coated combustion chamber is to be studied

**Acknowledgements**

Authors thank authorities of Chaitanya Bharathi Institute of Technology, Hyderabad for facilities provided. The financial assistance from Andhra Pradesh Council of Science and Technology (APCOST), Hyderabad, is greatly acknowledged.

**References**

Fulekar M H, Chemical pollution – a threat to human life, *Indian J Env Prot*, 1, 2004 353-359.

*Engineering Chemistry*, edited by B.K. Sharma [Pragathi Prakashan (P) Ltd, Meerut] 2004, 150-160

*Environmental Pollution Analysis*, edited by S.M Khopkar [New Age International (P) Ltd, Publishers, New Delhi] 2005, 180-190

Ghose M K, Paul R and Benerjee S K, Assessment of the impact of vehicle pollution on urban air quality, *J Environ Sci & Engg*, 46, 2004, 33-40

Usha Madhuri T, Srinivas T and Ramakrishna K, A study on automobile exhaust pollution with regard to carbon monoxide emissions, *Nature, Environ & Poll Tech*, 2,2003, 473-474

Murthy, P.V.K., Narasimha Kumar, S., Murali Krishna, M.V.S., Seshagiri Rao, V.V.R. and Reddy, D.N., “Aldehyde emissions from two-stroke and four-stroke spark ignition engines with methanol blended gasoline with catalytic converter”, *International Journal of Engineering Research and Technology*, ISSN: 0974-3154, Volume- 3, Number- 3, 2010, pp: 793–802.

Nedunchezhian N & Dhandapani S , Experimental investigation of cyclic variation of combustion parameters in a catalytically activated two-stroke SI engine combustion chamber, *Engg Today*, 2,2000, 11-18.

Murali Krishna, M.V.S., Kishor, K., Murthy, P.V.K., Gupta, A.V.S.S.K.S. and Narasimha Kumar, S., “Performance evaluation of copper coated four stroke spark ignition engine with gasohol with catalytic converter”, *International Journal of Engineering Studies*, ISSN: 0975- 6469 Volume- 2, Number-4, 2010, 465-473.

Narasimha Kumar, S., Murali Krishna, M.V.S., Murthy, P.V.K., Seshagiri Rao, V.V.R. and Reddy, D.N., Performance of copper coated two stroke spark ignition engine with gasohol with catalytic converter " *International Journal on Mechanical & Automobile Engineering (IJMAE)*, ISSN: 0974 - 231X, 12(1), 36-43, 2011

Murali Krishna, M.V.S. and Kishor, K., “Control of pollutants from copper coated spark ignition engine with methanol blended gasoline”, *Indian Journal of Environmental Projection*. 25(8), 732-738, 200

Murali Krishna, M.V.S., Kishor, K., Prasad, P.R.K. and Swathy, G.V.V., “Parametric studies of pollutants from copper coated spark ignition engine with catalytic converter with gasoline blended methanol”, *Journal of Current Sciences*, 9(2), 529-534,2006

Murali Krishna, M.V.S., Kishor, K. and Ramana Reddy, Ch. V., “Control of carbon monoxide emission in spark ignition engine with methanol blended gasoline and sponge iron catalyst”, *Ecology, Environment & Conservation*. 13(4), 13:17, 2008.

Murali Krishna, M.V.S. and Kishor, K., “Investigations on catalytic coated spark ignition engine with methanol blended gasoline with catalytic converter”, *Indian Journal (CSIR) of Scientific and Industrial Research*, Volume-67, July, 543-548,2008.

Kishor, K., Murali Krishna, M.V.S., Gupta, A.V.S.S.K.S., Narasimha Kumar, S. and Reddy, D.N., “Emissions from copper coated spark ignition engine with methanol blended gasoline with catalytic converter”, *Indian Journal of Environmental Protection*, 30(3), 2010, 177-1

Ceviz, M.A. and Yu ksel, F., “Effects of ethanol–unleaded gasoline blends on cyclic variability and emissions in a spark ignition engine”, *Applied Thermal Engineering*, Volume- 25, 917–925, 200

Bahattin Celik, M., “Experimental determination of suitable ethanol–gasoline blend rate at high compression ratio for gasoline engine”, *Applied Thermal Engineering*, Volume-28, 396–404, 2008

Al-Baghdadi., “Measurement and prediction study of the effect of ethanol blending on the performance and pollutants emission of a four-stroke spark ignition engine”, *Proceedings of the Institution of Mechanical Engineers*, Volume- 222, Number- 5, 859-873, 2008