

Research Article

Electrochemical Studies of Photogalvanic Cell Consisting of Dye-Reductant in Micelles Media for Solar Energy Conversion and Storage

A.S. Meena^{Å*}^ÅDepartment of Chemistry, MLS University, Udaipur, Rajasthan-313001 (INDIA).Accepted 05 November 2013, Available online 01 December 2013, **Vol.3, No.4 (Dec 2013)**

Abstract

Electrochemical studies of solar cell consisting of dye-reductant in micelles media for solar energy conversion and storage. The photovoltages and photocurrents in photogalvanic cell containing a Methylene blue-EDTA and TX 100 as surface active agent has been determined. The photo-outputs Methylene blue-EDTA-TX 100 are higher than Azur B-EDTA-CTAB system. The efficiency of the Methylene blue-EDTA and TX 100 in photogalvanic cell has been estimated to be 1.087%. The photopotential and photocurrent generated, Fill factor and storage capacity of the photogalvanic cells is determined. The effects of different parameters on electrical output of the cell are observed. The mechanism has also been proposed for the generation of the photocurrent in photogalvanic cell.

Keywords: photopotential, photocurrent, conversion efficiency, fill factor, storage capacity

Introduction

The photogalvanic cells are the better sources of electric power during the sunshine hours, and may also be a reliable source of solar power even in the absence of sunshine due to better storage capacity. They are virtually free of pollution. Photogalvanic cells are those cells in which solar energy convert into electrical energy via formation of energy rich species that exhibit the photogalvanic effect. This cell works on photogalvanic effect. The photogalvanic effect was first of all recognised by Rideal and Williams [1925] and it was systematically studied by Rabinowitch [1940], Potter and Thaller [1959], Wolf [1960], Rohatgi-Mukherjee et al. [1983]. Dixit and Mackay [1982] and Kamet [1985] study various systems in photogalvanic cell for solar energy conversion and storage. Study of enhancement in the performance and power output of dye-sensitized solar cells based on TiO₂ nanocrystals films by Ameta et al. [1989], Jana et al. [1999] and Peng et al. [2003]. Optimum efficiency of photogalvanic cell for solar energy conversion has been studied by Albery and Archer [1977]. Gangotri et al. [1997, 2005 and 2001], Madwani et al. [2007] and Genwa and his coworkers [2006, 2009 and 2012] have been used of some reductant, photosensitizer and surfactant in photogalvanic cells for conversion of solar energy in to electrical energy. Gangotri and his co-workers [2010 and 2011] have been studied of photogalvanic cell for solar

energy conversion and storage by using some dye with reductant, mixed dye, mixed reductant and dye with reductant and micelles. Recently, some photogalvanic cells were developed on the basis of role of photosensitizer with reductant for generation of electrical energy by Chandra and Meena [2010 and 2011], Chandra [2012] and Chandra et al. [2012]. The research in the field of photogalvanic cells is still in its infancy with respect to its viability and practical applicability and, therefore, requires thorough exploration to increase the conversion efficiency and storage capacity by selecting a suitable redox couple, dye and micelles. Therefore, the present system is undertaken.

2. Materials and Methods

Methylene blue (RANKEM), Azur B (MERCK), EDTA (MERCK), TX 100 (LOBA), CTAB (MERCK) and NaOH (MERCK) are used with purification in present work. All the solutions are prepared in doubly distilled water and the stock solutions of all chemicals are prepared by direct weighing and are kept in coloured container to protect them from the light. The solution is bubbled with prepurified nitrogen gas for nearly twenty minutes to remove dissolved oxygen. Solutions of dye, reductant, micelles and sodium hydroxide are taken in an H-type glass tube. A platinum electrode (1.0 x 1.0 cm²) is immersed into one arm of H-tube and a saturated calomel electrode (SCE) is kept in the other. The whole cell is first placed in dark till a stable potential is obtained and then, the arm containing the SCE is kept in the dark and the platinum electrode is exposed to a 200.0 W tungsten lamp.

*Corresponding Author Address: - Solar Energy Lab, Department of chemistry, MLS University, Udaipur, Rajasthan (INDIA) – 313001 and Tel. No.:- +919785837989.

A water-filter is used to cut off infrared radiations. The photochemical bleaching of Methylene blue is studied potentiometrically. A digital pH meter (Systronics Model-335) and a microammeter (Ruttonsha Simpson) are used to measure the potential and current generated by the cell, respectively. The current–voltage (i-V) characteristics of photogalvanic cell have been studied by applying an external load with the help of a carbon pot (log 470 K) connected in the circuit through a key to have close circuit and open circuit device. The experimental set-up of photogalvanic cell is given in Figure-1. The effect of variation of different parameters has also been observed. The rate of change in potential after removing the source of illumination is 0.93mVmin^{-1} in Methylene blue-EDTA-TX 100 cell; therefore, the system may be used in photogalvanic cell more successfully than the Azur B-EDTA-CTAB cell.

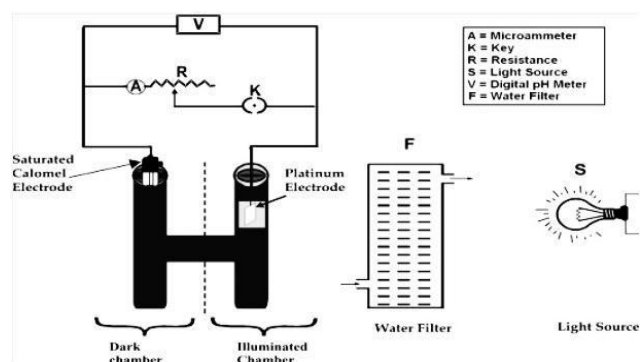

Figure 1 Experimental set-up of photogalvanic cell

3. Results and Discussion

3.1 Variation of photopotential with time in Methylene blue-EDTA-TX 100 system

The photopotential of Methylene blue- EDTA-TX 100 system is measured at different pH values and maximum photopotential is found at pH 11.60. All the subsequent measurements are made at this pH value. The variation of photopotential with time for this system is shown in Figure 2. As can be seen from the figure that the photopotential

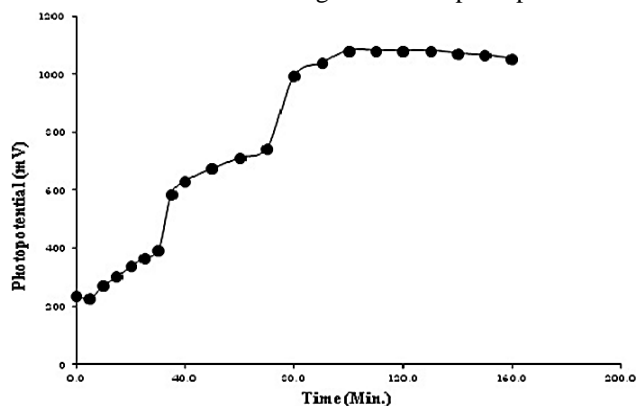

Figure 2 Variation of Photopotential with Time Methylene blue-EDTA-TX 100 System

increase upon illumination to a value of 1082.0 mV in about 130.0 minutes and remains constant on further illumination. When the light is switched-off, the system does not regain its original potential; thereby, showing that the system is not perfectly reversible.

3.2 Variation of photopotential with time in Azur B-EDTA-CTAB system

The photopotential of Azur B-EDTA-CTAB system is measured at different pH values and maximum photopotential is found at pH 13.20. All the subsequent measurements are made at this pH value. The variation of photopotential with time for this system is shown in Figure 3. As can be seen from the figure that the photopotential increase upon illumination to a value of 1035.0 mV in about 150.0 minutes and remains constant on further illumination. When the light is switched-off, the system does not regain its original potential; thereby, showing that the system is not perfectly reversible. The observed photopotentials and photocurrents in Azur B-EDTA-CTAB system are comparable less than that of the Methylene blue-EDTA-TX 100 system (Table 1).

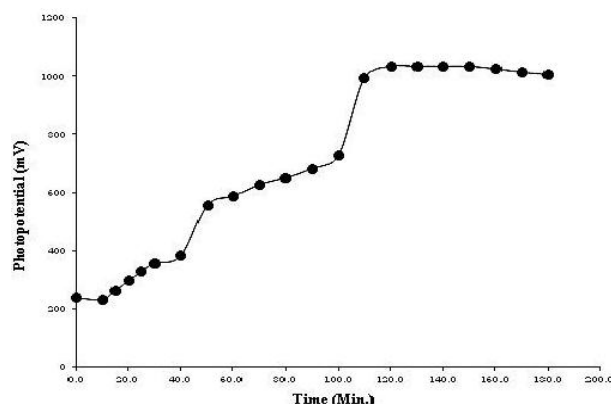

Figure 3 Variation of Photopotential with Time in Azur B-EDTA-CTAB System

Table-1 Electrical output of photogalvanic cell

S. No.	Parameter	Observed value in Methylene blue-EDTA-TX 100 system	Observed value in Azur B-EDTA-CTAB system
1.	Dark potential	237.0 mV	240.0 mV
2.	Open circuit voltage (Voc)	1082.0 mV	1035.0 mV
3.	Photopotential (DV)	845.0 mV	795.0 mV
4.	Equilibrium photocurrent (i_{ss}/i_{sc})	420.0 μA	395.0 μA
5.	Maximum photocurrent (i_{max})	490.0 μA	475.0 μA
6.	Initial generation of photocurrent	24.5 $\mu\text{A min}^{-1}$	19.0 $\mu\text{A min}^{-1}$
7.	Time of illumination	130.0 min	150.0 min
8.	Storage capacity ($t_{1/2}$)	160.0 min	140.0 min
9.	% of storage capacity of cell	123.07%	93.33%
10.	Conversion efficiency	1.087%	1.004%
11.	Fill factor (η)	0.2488	0.2556

[Methylene blue] = 2.04×10^{-5} M; Light Intensity = 10.4 mW cm^{-2} ; [EDTA] = 1.20×10^{-3} M; Tempt. = 303 K; [TX 100] = 0.84×10^{-3} M; pH = 11.60

[Azur B] = 1.88×10^{-5} M; Light Intensity = 10.4 mW cm^{-2} ; [EDTA] = 1.16×10^{-3} M; Tempt. = 303 K; [CTAB] = 0.68×10^{-3} M; pH = 13.20

3.3 Variation of photocurrent with time in photogalvanic cell

The photo induced short circuit currents of Methylene blue-EDTA-TX 100 system and Azur B-EDTA-CTAB system in photogalvanic cells are shown in Figure 4. On illumination, maximum photocurrents 475.0 μA is obtained in 150.0 minutes in Azur B-EDTA-CTAB system and 490.0 μA in 130.0 minutes in Methylene blue-EDTA-TX 100 system. The Methylene blue-EDTA-TX 100 system takes much smaller time than Azur B-EDTA-CTAB system. The trend in short circuit photocurrents of Methylene blue-EDTA-TX 100 system is much better than Azur B-EDTA-CTAB system (Table 1).

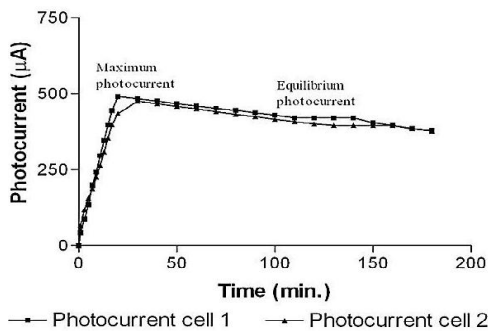

Figure 4 Variation of Photocurrent with Time in Cell I & II Methylene blue-EDTA-TX 100 & Azur B-EDTA-CTAB system respectively.

3.4 Conversion efficiency of photogalvanic cell

Conversion efficiency is the important characteristics of any photogalvanic cell. The current-voltage (i-V) characteristics of Methylene blue-EDTA-TX 100 system and Azur B-EDTA-CTAB system in photogalvanic cells have been investigated to estimate the power conversion efficiency of the cell. The maximum possible power output from the cell can be obtained from the rectangle of maximum area, which can be drawn under i-V curve. The power points (a point on the curve, where the product of potential and current was maximum) in i-V curves are determined and their fill factors and conversion efficiency are also calculated by using the formula.

$$\text{Fill factor } (\eta) = \frac{V_{pp} \times I_{pp}}{V_{oc} \times I_{sc}} \quad (1)$$

$$\text{Conversion Efficiency} = \frac{V_{pp} \times I_{pp}}{10.4 \text{ mW}} \times 100\% \quad (2)$$

Observed data of fill factor for these two systems are summarized in Table 2. The conversion efficiency of the Methylene blue-EDTA-TX 100 photogalvanic cell has been calculated to be 1.087% and that of Azure B-EDTA-CTAB photogalvanic cell has been calculated to be 1.004%. The conversion efficiency and sunlight

conversion data for these two systems are reported in Table 3. On the basis of these observations data, the higher conversion efficiency is found in Methylene blue-EDTA-TX 100 photogalvanic cell.

Table-2 i-V Characteristics of the cell

System	V_{oc} (mV)	I_{sc} (μA)	V_{pp} (mV)	I_{pp} (μA)	η
Methylene blue-EDTA-TX 100	1082.0	420.0	514.0	220.0	0.2488
Azur B-EDTA-CTAB	1035.0	395.0	550.0	190.0	0.2556

Table-3 Conversion efficiency and sunlight conversion data

System	Fill Factor (η)	Conversion Efficiency (%)	Sunlight conversion data	
			Potential (mV)	Currents (μA)
Methylene blue-EDTA-TX 100	0.2488	1.087	1082.0	490.0
Azur B-EDTA-CTAB	0.2556	1.004	1035.0	475.0

3.5 Performance of the photogalvanic cell

The performance of the photogalvanic cell is observed by applying an external load (necessary to have current at power point) after terminating the illumination as soon as the potential reaches a constant value. The performance is determined in terms of $t_{1/2}$, i.e., the time required in the fall of the output (power) to its half at power point in dark. The performance of cells and $t_{1/2}$ are summarized in the Table 4. On the basis of the observed results, the Methylene blue-EDTA-TX 100 is the more efficient photogalvanic cell from power generation and performance point of view.

Table-4 Performance of the photogalvanic cell in dark

System	Power (μW)	$t_{1/2}$ (min.)
Methylene blue-EDTA-TX 100	113.80	160.0
Azur B-EDTA-CTAB	104.50	140.0

4. Mechanism

On the basis of these observations, a mechanism is suggested for the generation of photocurrent in the photogalvanic cell as:

4.1 Illuminated chamber

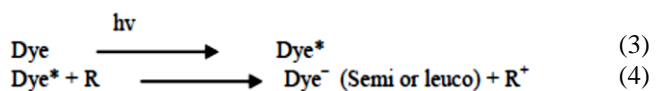

At platinum electrode

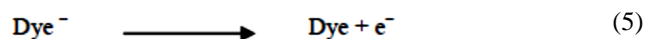

4.2 Dark chamber

At calomel electrode

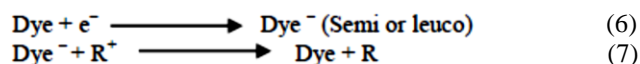

The process of mechanism in photogalvanic cell is also represented in Figure 5.

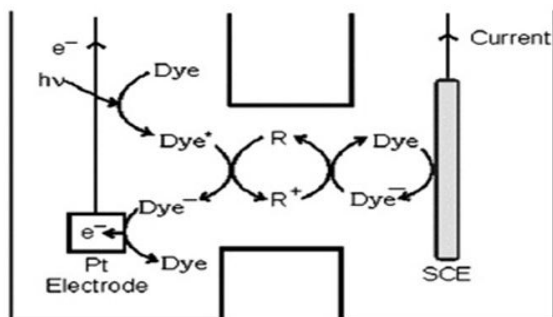

Figure 5 Processes of mechanism in photogalvanic cell

Conclusion

Photogalvanic cells are cheaper due to the use of a dye and reductant in micelles media, which are lower in cost and used in minute quantities of dye, reductant and micelles. On the basis of results in the present study, it is concluded that nonionic micelles have higher electrical output than cationic micelles in photogalvanic cell. Also this system with better electrical output good performance and storage capacity may be used in near future. According to results of photogalvanic cell in these two systems, Methylene blue-EDTA-TX 100 system is the more efficient than Azur B-EDTA-CTAB system.

Acknowledgement

The author (A.S. Meena) is grateful to The Head, Department of Chemistry, MLS University, Udaipur (Raj.)- 313001 (INDIA) and Ministry of New and Renewable Energy (MNRE), Government of India, New Delhi-110003 (INDIA) for providing the necessary laboratory facilities and financial assistance to conduct this research work.

References

- E.K. Rideal and E.G. Williams, (1925), *J. Chem. Soc. Trans.*, 127, 258.
- E. Rabinowitch (1940), *J. Chem. Phys.*, 8, 551.
- E. Rabinowitch (1940), *J. Chem. Phys.*, 8, 560.
- A.E. Potter and L.H. Thaller (1959), *Solar Energy*, 3, 1.
- M. Wolf (1960), *Proc. I. R. E.*, 48, 1246.
- K.K. Rohatgi-Mukherjee, M. Roy and B.B. Bhowmik (1983), *Solar Energy*, 31, 417
- N.S. Dixit and R.A. Mackay (1982), *J. Phys. Chem.*, 86, 4593.
- P.V. Kamat (1985), *J. Chem. Soc., Faraday Trans.*, 1, 509.
- W.J. Albery and M.D. Archer (1977), *Nature*, 270, 399.
- S.C. Ameta, S. Khamesra, A. K. Chittora and K. M. Gangotri (1989), *Int. J. Energy Research*, 13, 643.
- A.K. Jana and B.B. Bhowmik (1999), *J. Photochem. Photobio. A: Chem.*, 122, 53.
- W. Peng, M.Z. Shaik, C. Pascal, C. Raphael, R. Humphry-Baker, and M. Gratzel (2003), *J. Phys. Chem. B*, 107, 14336.
- K.M. Gangotri and O.P. Regar (1997), *Int. J. Energy Research*, 21, 1345-1350
- K.M. Gangotri, and C. Lal (2005), *J. Power and Energy Part A*, 219, 315.
- K.M. Gangotri and R. C. Meena (2001), *J. Photochem. Photobio. A Chem.*, 141, 175.
- S. Madhwani, J. Vardia, P.B. Punjabi and V.K. Sharma (2007), *J. Power and Energy Part A*, 221, 33.
- S. Madhwani, R. Ameta, J. Vardia, P.B. Punjabi and V.K. Sharma (2007), *Energy Sources Part A*, 29, 721
- K.R. Genwa and N.C. Khatri (2006), *Int. J. Chem. Sci.*, 4, 70
- K.R. Genwa, A. Kumar and A. Sonel (2009), *Applied Energy*, 86, 1431.
- K.R. Genwa and A. Chouhan (2012), *Res. J. Rec. Science*, 1, 117.
- K.M. Gangotri and V. Indora, *Solar Energy* (2010), 84, 271.
- K.M. Gangotri and M.K. Bhimwal (2010), *Int. J. Elect. Power & Energy Systems*, 10, 1106
- K.M. Gangotri and M. K. Bhimwal (2011), *Energy Sources Part A*, 33, 2104
- K.K. Bhati and K.M. Gangotri (2011), *Int. J. Elect. Power & Energy Systems*, 33, 155
- K.M. Gangotri and M.K. Bhimwa (2011), *Energy Sources*, M.K. Bhimwal and K.M. Gangotri (2011), *Energy Sources*, 36, 1324.
- M. Chandra and R.C. Meena (2010), *Int. J. Chem. Sci.*, 8, 1447
- M. Chandra and R.C. Meena (2011), *Res. J. Chem. Sci.*, 1, 63.
- M. Chandra and R.C. Meena (2011), *J. Chem. & Pharm. Research*, 3(3), 264.
- M. Chandra (2012), *Res. J.Pharm. Biological & Chemical*, 3(2), 158.
- M. Chandra, A. Singh and R.C. Meena (2012), *Int. J. Physical Sciences*, 7, 5642.