

Research Article

A Novel Unified Power Quality Conditioning System for Power Quality Improvement and Bidirectional Power Flow Control for Windmill

Gl.Valsala^{a*} and L .Padmasuresh^a

^aDept of EEE,Noorul Islam University, Tamilnadu,India

Accepted 25 May 2013, Available online 1 June 2013, Vol.3, No.2 (June 2013)

Abstract

This paper proposes a new approach of unified power quality conditioner which is made up of a matrix converter to mitigate the current harmonics, voltage sags and swells and control the power flow with Bi directional capability for windmill. Matrix converter injects the compensation voltage on the load-side, so it is possible to mitigate the voltage sag/swell problems, resulting in an efficient solution for mitigating voltage and current related power quality problems. Thus, the proposed topology can mitigate the voltage fluctuations and current harmonics without energy storage elements and the total harmonic distortion produced by the system also very low. Due to the bidirectional power flow capability of matrix converter the proposed unified power quality conditioner capable to control the power flow of the windmill more over it also transfer power bi -directional. The space-vector modulation (SVM) is used to control the matrix converter. Matlab/Simulink based simulation results are presented to validate the approach.

Key words: Matrix Converter, unified power quality conditioner, current harmonics, voltage sag/swell, Non linear load, windmill, Matlab/Simulink.

1. Introduction

Power quality is the set of limits of electrical properties that allows electrical system to function in a proper manner . Power quality problems produced by a large increase of the load current, like starting a motor or transformer energizing. The flexible AC transmission system (FACTS), improve the reliability and quality of power transmission system, the custom power devices enhance the quality and reliability of power that is delivered to customers(Pal, Y et al, 2008). The main causes of a poor power quality at customer side are harmonic currents, poor power factor, supply voltage variations, etc. (Siahkali, H 2008). In recent years the demand for the quality of electric power has been increased rapidly.

Unified power quality conditioner (UPQC) is one of the best customs Power devices used to compensate both source and load side problems (Khadkikar, V,2012). It consists of shunt and series converters connected back to back to a common DC link. It can perform the functions of both D-statcom and DVR. Fig. 1 shows a basic system configuration of a general UPQC consisting of the combination of a series active filter and shunt active filter (Fujita, H., et al, 2001).The main aim of the series active filter is harmonic isolation between a distribution system and a load. It has the capability of voltage flicker/

imbalance compensation as well as voltage regulation and harmonic compensation at the utility-consumer point of common coupling (PCC). The shunt active filter is used to absorb current harmonics, compensate for reactive power and negative-sequence current, and regulate the DC-link voltage between both active power filters (Muthazhagi, M.;et al 2012).

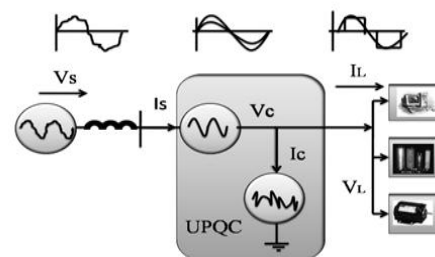

Fig 1: basic structure of unified power quality conditioner

Unified power quality conditioner consists the DC bus and its DC capacitor must be designed. Dec capacitor achieves two goals, i.e., to comply with the minimum ripple requirement of the DC bus voltage and to limit the DC bus voltage variation during load transients. But the proposed matrix converter based UPQC there is no need of DC capacitor.

All the series active filter is controlled by the voltage source converter. But voltage source converter has some

*Corresponding author: Gl.Valsala

draw back present. Due to switching loss, capacitor leakage current, etc., the distribution source must provide not only the active power required by the load but also the additional power required by the VSI to maintain the DC-bus voltage constant. Unless these losses are regulated, the DC-bus voltage will drop steadily. Moreover VSC based converter produces more harmonics and switching losses high.

The windmill is the most important non conventional energy source. Various wind turbine generators available to convert wind energy to electrical energy. Particularly induction type wind turbine generator is commonly used for its rugged construction ,long life and more power handling capacity. This type of windmill affected by power quality problems like voltage sag,swell and current harmonics (Tadeusz LOBOS et al,2008).Induction type wind generator initially drawn current from the grid and deliver power through same grid.here the power is bidirectional. Many FACTS are used to solve the power quality issues in windmill (Yuvaraj, V.,et al,2011).Conventional unified power quality conditioner VSC based converter used,which is unidirectional. So conventional power unified quality conditioner not suitable for induction type windmill.

In this paper a matrix converter based unified power quality conditioner compensates voltage sag and swell and current harmonics compared and bidirectional power flow capability

2. Matrix Converter

In this paper proposes a matrix converter based unified power quality conditioner for wind mill instead of VSC based unified power quality conditioner. Although matrix converter was initially introduced as an AC Driver, due to its advantages may be used in voltage compensation applications like series active filter, DVR (Abardeh, M.H.etal 2010)and shunt active filter (Heris, A et al 2012). A matrix converter can operate as a four quadrature Ac-Ac converter circuit. The output voltage, frequency and its amplitude and also the input power factor can be controlled by utilizing the proper modulation method (SVM). The main drawbacks of this topology are the need for fully controlled bi-directional switches and complex algorithm to perform commutation. The nine matrix converter switches can be represented as a 3x3

$$S = \begin{bmatrix} S_{11} & S_{12} & S_{13} \\ S_{21} & S_{22} & S_{23} \\ S_{31} & S_{32} & S_{33} \end{bmatrix} \tag{1}$$

The relationship between load and input voltages can be expressed as

$$[v_A v_B v_C]^T = S [v_a v_b v_c]^T \tag{2}$$

Input phase currents can be related to the output phase currents (9), using the transpose of matrix

$$[i_a i_b i_c]^T = S^T [i_A i_B i_C]^T \tag{3}$$

3. Proposed Unified Power Quality Conditioner for windmill

The proposed unified power quality conditioner for wind mill is designed using a matrix converter is shown if figure 3. I_{abc} are the smoothing inductor. $C_{(abc)}$ is the smoothing capacitor. One step up transformer is used for step up the matrix converter input voltage. So the matrix converter injects the significant current to PCC for current harmonic mitigation.

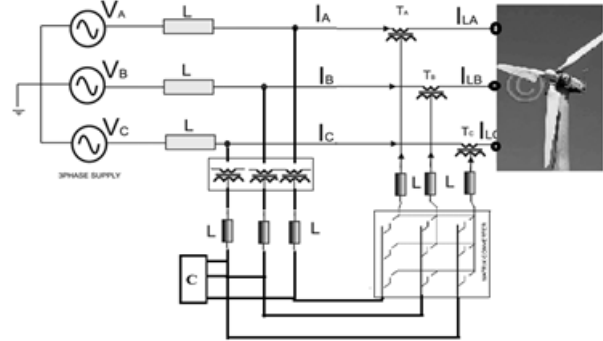

Fig 3: Proposed unified power quality conditioner

In this paper, the step up transformer was simply modeled by a current source (i_{trans})and the focus to put on the control of the input current for the active filtering function. Because matrix converter transfer ratio is limited to 0.876.

In series part a unified power quality conditioner is designed using the same matrix converter topology .Series filter removes the voltage ripples. The series transformer also called injection transformer which injects the appropriate voltage to the load to compensate the voltage and removes the harmonics.more over the series part control the power flow bi directionally by adjusting the matrix converter switching.

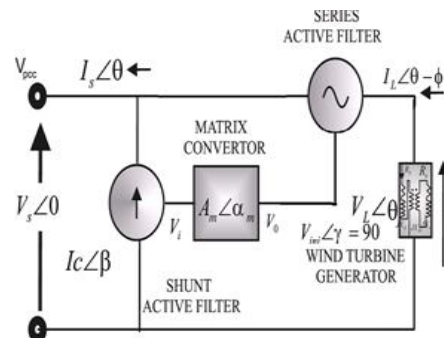

Fig 4: fundamental diagram of proposed unified power quality conditioner connected to an induction wind turbine Generator

$v_{inj} \angle \gamma = 90$ is the injection voltage for voltage compensation. UPQC's series active filter work as isolators, instead of generators of harmonics and, hence, they use different control strategies. Now, here UPQC's series active filters working as controllable voltage sources. With this approach, the evaluation of the

reference voltage for the series filter is and shunt active filter required.

4. The control system of Matrix Converter Based Unified Power Quality Conditioner for windmill.

4.1 Series part control system of UPQC

The output terminal voltage and input terminal current consider the low frequency transformation function (4) and set a sinusoidal input voltage, as follows:

$$\bar{v}_{abc} = V_i \begin{bmatrix} \cos(\omega_0 t + \alpha_0) \\ \cos(\omega_0 t + \alpha_0 - 2\pi/3) \\ \cos(\omega_0 t + \alpha_0 + 2\pi/3) \end{bmatrix} \tag{4}$$

$$\begin{aligned} \bar{v}_{ABC} &= D\bar{v}_{abc} = (aD_1 + (a-1)D_2)\bar{v}_{abc} \\ &= qV_i \begin{bmatrix} \cos(\omega_0 t + \alpha_0) \\ \cos(\omega_0 t + \alpha_0 - 2\pi/3) \\ \cos(\omega_0 t + \alpha_0 + 2\pi/3) \end{bmatrix} \end{aligned} \tag{5}$$

Where ϕ is the output (or load) angle. Using equation (5), the MC output currents can be written as follows:

$$\bar{i}_{abc} = D^T \bar{i}_{ABC} = qI_o \left\{ a \begin{bmatrix} \cos(\omega_0 t + \phi_0) \\ \cos(\omega_0 t + \phi_0 - 2\pi/3) \\ \cos(\omega_0 t + \phi_0 + 2\pi/3) \end{bmatrix} + (1-a) \begin{bmatrix} \cos(\omega_0 t + \phi_0) \\ \cos(\omega_0 t + \phi_0 - 2\pi/3) \\ \cos(\omega_0 t + \phi_0 + 2\pi/3) \end{bmatrix} \right\} \tag{6}$$

Assume the desired input current to be

$$\bar{i}_{ABC} = I_o \begin{bmatrix} \cos(\omega_0 t + \alpha_0 + \phi_0) \\ \cos(\omega_0 t + \alpha_0 + \phi_0 - 2\pi/3) \\ \cos(\omega_0 t + \alpha_0 + \phi_0 + 2\pi/3) \end{bmatrix} \tag{7}$$

Where ϕ_i is the input displacement angle.

$$\bar{i}_{abc} = I_i \begin{bmatrix} \cos(\omega_i t + \alpha_i + \phi_i) \\ \cos(\omega_i t + \alpha_i + \phi_i - 2\pi/3) \\ \cos(\omega_i t + \alpha_i + \phi_i + 2\pi/3) \end{bmatrix} \tag{8}$$

4.2 Power flow control

Considering a symmetrical and balanced three-phase system and applying Kirchoff laws to the AC line currents are obtained in coordinates

$$\frac{di_d}{dt} = \omega i_q - \frac{R_2}{L_2} i_d + \frac{1}{L_2} (vL_d - vRO_d) \tag{9}$$

$$\frac{di_q}{dt} = \omega i_d - \frac{R_2}{L_2} i_q + \frac{1}{L_2} (vL_q - vRO_q) \tag{10}$$

The active and reactive power of end generator is given in dq coordinates by

$$\begin{bmatrix} P \\ Q \end{bmatrix} = \begin{bmatrix} v_d & v_q \\ v_q & -v_d \end{bmatrix} \begin{bmatrix} i_d \\ i_q \end{bmatrix} \tag{11}$$

The active and reactive power P and Q are given by (12) and (13) respectively

$$Q = -v_d i_q \tag{12}$$

$$P = v_d i_d \tag{13}$$

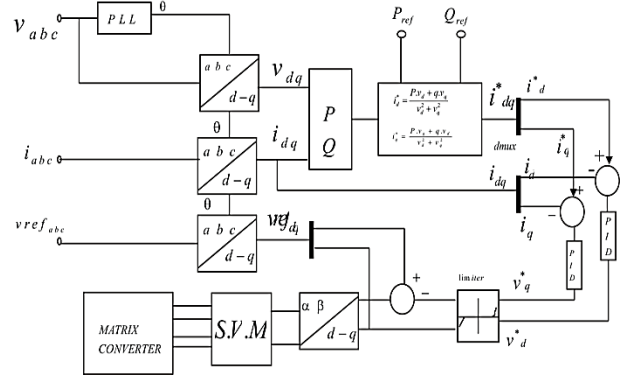

Fig 5:Control system of series part of proposed unified power quality conditioner

$$i^*_d = \frac{P \cdot v_d + q \cdot v_q}{v_d^2 + v_q^2} \tag{14}$$

$$i^*_q = \frac{P \cdot v_q + q \cdot v_d}{v_d^2 + v_q^2} \tag{15}$$

Reference dq currents converted to a reference voltage as shown in equation

$$v^*_d = i_d - i^*_d \tag{16}$$

$$v^*_q = v_q - v^*_q \tag{17}$$

For space vector modulation dq values converted to $\alpha\beta$ coordinates.

4.2 shunt part control system of UPQC

The load current is measured and transformed from the fixed abc-reference frame to the rotating dq-reference frame using the relation (18) and the angle of the voltage at the Point of Common Coupling (PCC).

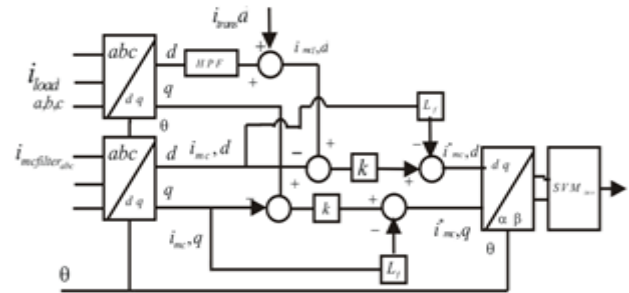

Fig 6:Control system of shunt part of proposed unified power quality conditioner

$$\begin{bmatrix} i_d \\ i_q \end{bmatrix} = \frac{2}{3} \begin{bmatrix} \cos \theta & \cos(\theta - \frac{2\pi}{3}) & \cos(\theta + \frac{2\pi}{3}) \\ \sin \theta & \sin(\theta - \frac{2\pi}{3}) & \sin(\theta + \frac{2\pi}{3}) \end{bmatrix} \begin{bmatrix} i_a \\ i_b \\ i_c \end{bmatrix} \tag{18}$$

Since the rotating dq-reference frame is based on the angle of the voltage at the PCC, the d and q load current components represent respectively the active and reactive components of the load current. The control objective is to compensate all the load current components except for the

fundamental active load current component. Therefore a High Pass Filter (HPF) is introduced to filter out the fundamental component of the active current. Only the harmonic and reactive components remain in the current reference. The active current that is produced by the transformer also needs to be added to the active current reference as the matrix converter. Finally are obtained the references d^*_{mc} q^*_{mc} and which are provided to the outer current control loop. All entities marked with asterisk are reference values as opposed to real/measured values. To control the current we use eq. (19)

$$L_f \frac{d}{dt} \overline{i_{mc}} = \overline{v_{pcc}} - \overline{v_c} \tag{19}$$

When eq. (20) is converted into the rotating dq -reference frame, cross-coupling terms appear as shown in eq. (21) Which must be compensated. When transforming to the rotating dq reference frame again cross coupling terms appear

$$C_f \frac{d}{dt} \begin{bmatrix} v_{c-d} \\ v_{c-q} \end{bmatrix} = \begin{bmatrix} i'_{mc,d} \\ i'_{mc,q} \end{bmatrix} - \begin{bmatrix} i_{mc,d} \\ i_{mc,q} \end{bmatrix} - \omega C_f \begin{bmatrix} -v_{c,q} \\ v_{c,d} \end{bmatrix} \tag{20}$$

$$L_f \frac{d}{dt} \begin{bmatrix} i_{mc-d} \\ i_{mc-q} \end{bmatrix} = \begin{bmatrix} v_{pcc} \\ 0 \end{bmatrix} - \begin{bmatrix} v_{c,d} \\ v_{c,q} \end{bmatrix} - \omega L_f \begin{bmatrix} -i_{mc,q} \\ i_{mc,d} \end{bmatrix} \tag{21}$$

Table 1: Simulation parameter of matrix converter based UPQC

Parameter	Value
V _{source}	440v
L _s	2mh
L _f	0.5mh
C _f	200µf
R _f	0.1Ω
C _i	2µf
Matrix converter Switching frequency	1200Hz
Power system frequency	60Hz

Table 1. Shows the system parameters of the proposed matrix converter based series active filter

5. Simulation results

In this work three phase matrix converter based unified power quality conditioner used to compensate the voltage sag/swell,current harmonics and control power flow and transfer power bi-directional for an induction wind mill connected network. The source voltage is 440Vrms, 60Hz. Table 1 shows the proposed system main parameters. It includes source impedance parameters L and C values for passive branches used system has been simulated. All the simulation is performed by the Matlab/ Simulink model in

discrete form. The sample time of the discrete value is 3x10⁻⁴sec.

5.1. Result For proposed UPQC based compensation for current harmonics.

Figure 7 shows the matrix converter based shunt active filter to mitigate the current harmonics efficiency compared to conventional techniques. Figure 7. (a) Shows the supply voltage and the waveform is sinusoidal. Figure7. (b) Shows the waveform of current after proposed compensation. The wave form also sinusoidal and the harmonic content is passive branches used system has been simulated. All the simulation is performed by the Matlab/ Simulink model in discrete form. The sample time of the discrete value is 3x10⁻⁴sec. Low/. Figure 7. (c) Shows the total harmonic distortion level. The total harmonic distortion is 2% only. It is clear from figure 7. (c) that the current injected by the matrix converter compensates the harmonic of the nonlinear load. The THD of the source current is reduced from 30% to 2%.

5.2. Result In proposed UPQC based compensation for voltage sag /swell condition

Figure 8 shows the single phase representation of the proposed unified power quality conditioner in another case2. The supply voltage is 440 volts and load also reduced. Figure. 8a shows the supply voltage at sag and swell conditions. At 0.1 sec to 0.2the voltage sag accrued the voltage sag voltage is at 100 volts .Moreover the voltage sag accrued at 0.3 sec to 0.4 sec of 50 volts. Figure 8.b shows the matrix converter based compensation compensate the voltage sag and swell. Figure 8 .c shows the output of the matrix converter total harmonic distortion. It contains less than 2% of harmonic present.

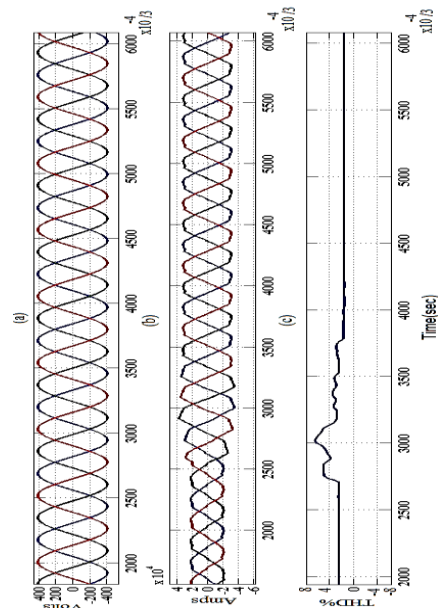

Fig 7: proposed matrix converter controlled current harmonic mitigation (a)Supply voltage (b) supply current

after proposed compensation (c) total harmonic distortion of supply current

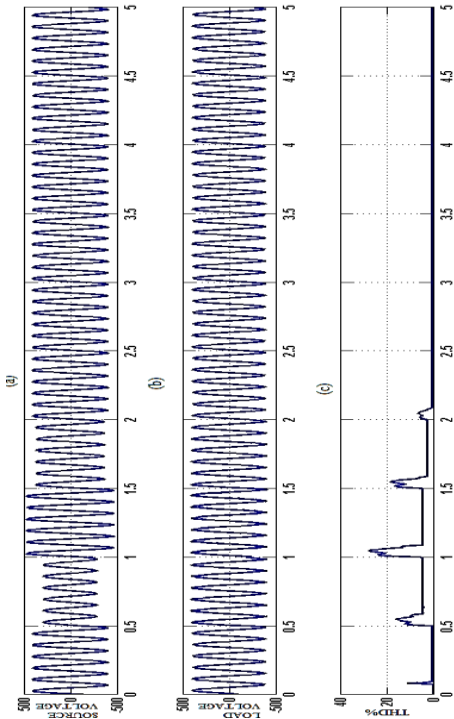

Fig 8: proposed matrix converter based UPQC voltage compensation (single phase) (a) Load voltage after proposed compensation (b) supply voltage (c) total harmonic distortion of load voltage

5.3 Result For injected voltage for voltage sag and swell conditions

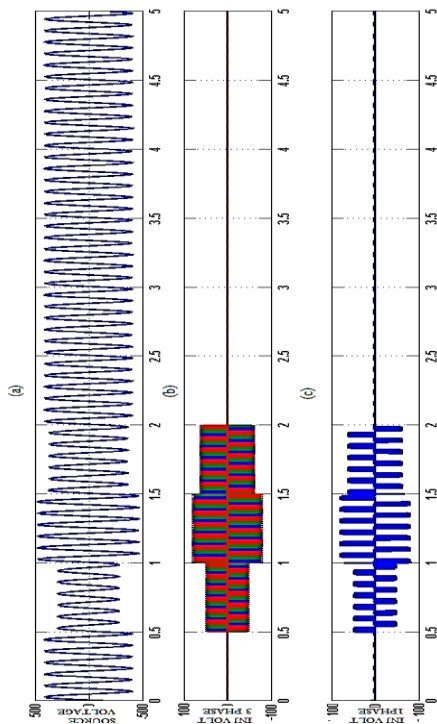

Fig9: injected voltage (a) supply voltage (b) injected voltage3 phase (3phase) (c) injected voltage (single phase) Figure 9 shown the voltage injection through proposed unified power quality conditioner. Figure 9. (a) Shows the fluctuated voltage. The

Figure 9. (b) Shows the corresponding injected voltage through the transformer and its matrix converter output voltage shown in figure 9(c).

5.4 Result For power flow control using a matrix converter based UPQC

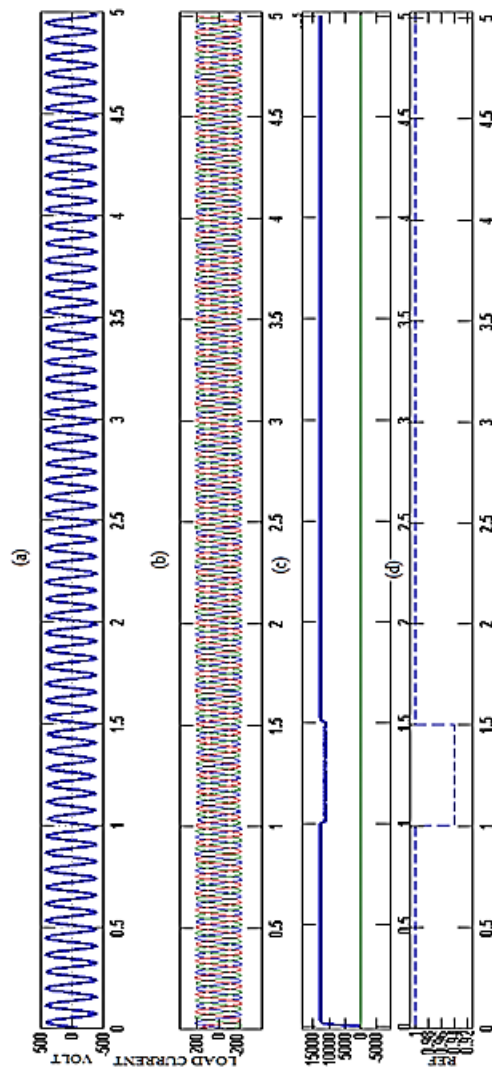

Fig10:power flow control using a matrix converter based unified power quality conditioner

Fig 10 shows the power flow control using the proposed matrix converter based unified power quality conditioner. fig10.(a) shows the load voltage. the nominal load voltage is 440 v. Fig 10. (b) Shows the load current.fig10.(c) shows the real power is controlled at 1 sec to 1.5 sec.figure 10. (d) Shows the P ref

Value. The P Reference value set 1 per unit. So the full power is allowed to the load via unified power quality conditioner. after 1 sec the power is set at 0.94 per unit. Up to 1.5 sec/. The unified power quality conditioner series part controls the power as shown the simulation result.

5.5 Result For power flow control using a matrix converter based UPQC

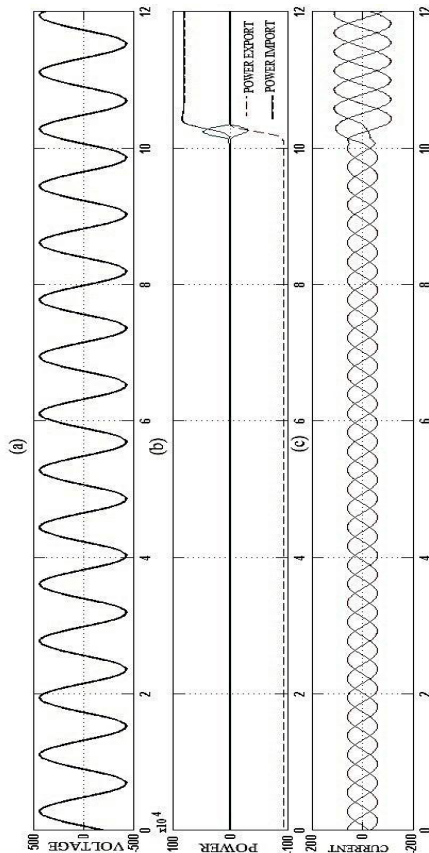

Fig 11: bi-directional power flow using a matrix converter based unified power quality conditioner

Fig 11 shows the bidirectional power flow capability of matrix converter based unified power quality conditioner connected windmill

Fig11 (a) shows the windmill terminal voltage of 440volts.figure11 (b) shows the wind mill's power is fed to grid from 0sec to 10 sec.So the matrix converter based unified power quality conditioner transfer power from the load side to source side hence the the power flow is negative. After 10.3 sec the wind mill is disconnected from the load side. So the the power transfer is stopped and the load consumes power from the source side.so the power flow is another direction as shown in figure power 11.(b). Fig 11 (c)shows the corresponding current from the source. due to wind mill connected to load side the source side load demand is shared by the wind mill power. after disconnecting the wind mill at 10.3 sec the source current is increased as shown.

6. Conclusion

In this paper investigated the use of matrix converter based unified power quality conditioner to mitigate the voltage sag/swell ,current harmonics and power flow. This paper also analyzed the bidirectional power capability Unified Power Quality Conditions.This can be achieved by change switching of matrix converter .The proposed UPQC's Series active filter handles both balanced and unbalanced Situations without any difficulties and injects the appropriate voltage component to correct any abnormalities in the supply voltage to keep the load voltage balanced and constant at the nominal Value. Moreover this control the power to the load also.The proposed unified power quality conditioner is implemented to wind mill the power transfer also achieved. Moreover the shunt control system controls the remove the current harmonic of load.Based on simulation results the matrix converter based UPQC also mitigates the current harmonics efficiently with low total harmonic distortion,voltage ag and swell and control the power flow bidirectional.

References

- Pal, Y., Swarup, A.,Singh, B. (2008) ,A Review of Compensating Type Custom Power Devices for Power Quality ImprovementIEEE International Conference on Power System Technology, pp 1 - 8.
- Siahkali, H (2008) Power quality indexes for continue and discrete disturbances in a distribution areaIEEE International Power and Energy Conference, pp.678 – 683
- Khadkikar, V (2012) Enhancing Electric Power Quality Using UPQC: A Comprehensive Overview' IEEE Transactions on Power Electronics,Vol: 27 , no: 5 , pp 2284 – 2297
- Fujita, H., Akagi, H. (2000) The unified power quality conditioner: the integration of series and shunt-active filters IEEE Transactions on Power Electronics, Vol.13 , no. 2 , pp .315 – 322
- Muthazhagi, M.; Kumar, N.S. (2012) Comparison of controllers for power quality improvement employing shunt active filterInternational Conference on Computing, Electronics and Electrical Technologies, ,pp 248 – 253,.
- Tadeusz LOBOS, Jacek REZMER(2008),Power Distortion Issues in Wind Turbine Power Systems Under Transient States Journal of Electrical Engineering , Vol.16, No.3, pp230-240,.
- Yuvaraj, V., Pratheep Raj, E., Mowlidharan, A., Thirugnanamoorthy, L. (2011). Power quality improvement for grid connected wind energy system using the FACTS device International Symposium on Theoretical Electrical Engineering , pp1-7,
- Abardeh, M.H.; Ghazi, R (2010)A new configuration for dynamic voltage restorer based-on matrix converter International Universities Power Engineering Conference , pp. 1 – 6,.
- Heris, A.A., Babaei, E., Hosseini, S.H A (2012) new shunt active power filter based on the indirect matrix converter Iranian Conference on Electrical Engineering ,pp. 581 - 586, .