

## Research Article

## Shape Memory Alloys and its Application in MEMS Devices

S.Mukesh Kumar<sup>a\*</sup> and M.Vanitha Lakshmi<sup>a</sup><sup>a</sup>S.A Engineering College, India

Accepted 5 March 2013, Available online 1 June 2013, Vol.3, No.2 (June 2013)

### Abstract

The position control in shape memory alloys are difficult because of its non-linear thermo mechanical behaviour, hence they are generally designed in two stable positions i.e. Austenite Phase (High temperature state) and Martensite Phase (Low temperature state). Shape memory alloys are the materials that has the ability to retain to its original shape when heated. SMAs has high resistivity that produces joule heating effect when current is applied. TiNi SMA has many properties which make it significant in MEMS devices. In this paper The NiTi - Si Shape memory thin film based microcantilever was designed which has three stable positions. The effect of temperature over the NiTi-Si thin film based microcantilever and the effect of change of structural dimensions of cantilever is analysed. It demonstrates a way to have multiple stable positions in an SMA device, which can have some significant advantages in many real engineering applications.

**Keywords:** Micro cantilever; Titanium Nickel (TiNi); Shape Memory Alloys(SMA); Micro Electro Mechanical Systems (MEMS); Joule heating.

### 1. Introduction

Shape Memory Alloys (SMAs) are metallic alloys that undergo a solid-to-solid phase transformation which can exhibit large recoverable strains. Shape-memory alloys (SMAs) possess an array of desirable properties: high power to weight (or force to volume) ratio, thus the ability to recover large transformation stress and strain upon heating and cooling, pseudo elasticity (or super elasticity), high damping capacity, good chemical resistance and biocompatibility (K. Otsuka et al,1999)(J.V. Humbeeck et al,1999).

When an SMA is cold, or below its transformation temperature, it has a very low yield strength and can be deformed quite easily into any new shape--which it will retain. However, when the material is heated above its transformation temperature it undergoes a change in crystal structure which causes it to return to its original shape. If the SMA encounters any resistance during this transformation, it can generate extremely large forces. This phenomenon provides a unique mechanism for remote actuation.

This attracted much attention to the research of SMAs as smart (or intelligent) and functional materials. More recently, thin film SMA has been recognized as a promising and high performance material in the field of micro-electro-mechanical system (MEMS) applications.

Attractive solutions have been achieved by using shape memory alloys (SMAs).

Besides high work outputs, further important features of SMA microdevices are compatibility to microelectronics, a high reliability due to an intrinsic actuation mechanism and a frictionless actuation. The position control in SMAs is not an easy matter as their thermomechanical behavior is nonlinear, with hysteresis and history dependent. Hence, most SMAs devices are designed for two positions only, i.e. a high temperature (austenite phase) position and a low temperature (martensite phase) position (W.M. Huang et al,2004). A fabrication concept based on the lateral micromachining of SMA sheets or films has been developed (M. Kohli et al,1994), which allows integration of several functional units in a single SMA piece and thus, a high flexibility in device design. Application of SMA in MEMS also facilitate simplification of mechanisms with flexibility of design and creation of clean, friction free and non-vibration movement.

In this paper, the NiTi-Si thin film based micro cantilever's three stable positions and the effect of changing the structural dimensions are discussed.

### 2. Nickel titanium shape memory alloy

Nickel Titanium, also known as NITINOL, it has the ability to undergo deformation at one temperature, then recover its original shape when heated. NiTi SMA is used in various MEMS devices such as Microcantilever, Microgripper, Micropumps and Micromirrors etc.

S.Mukesh Kumar is a Research Scholar and M.Vanitha Lakshmi is working as Asst. Prof

Some basic requirements for TiNi films used in MEMS applications are low residual stress to prevent deformation of MEMS structure, high actuation speed and fast response with precise control of deformation and strain, good adhesion on substrate (free of cracking, delamination and spallation), durable and reliable shape memory effects, wide range choice of working temperatures, good resistance to surface wear and corrosion, biocompatible and good corrosion resistance (in case of application in bio-MEMS). Some of the properties of NiTi SMA is given below

### 2.1 Properties of Nitinol [9,18-20]:

#### 2.1.1 Physical properties of Nitinol

- Density: 6.45gms/cc
- Melting Temperature: 1240-1310° C
- Resistivity (hi-temp state): 82  $\mu\text{ohm-cm}$
- Resistivity (lo-temp state): 76  $\mu\text{ohm-cm}$
- Thermal Conductivity: 18 W/m K
- Electrical Conductivity (hi-temp state):  $1.219 \times 10^{-6}$  S/m [21]
- Heat Capacity: 450 J/Kg\* K.
- Latent Heat: 5.78 cal/gm; 24.2 J/gm
- Magnetic Susceptibility (hi-temp): 3.8  $\mu\text{emu/gm}$
- Magnetic Susceptibility (lo-temp): 2.5  $\mu\text{emu/gm}$

#### 2.1.2 Mechanical properties of Nitinol

- Ultimate Tensile Strength: 754 - 960 MPa or 110 - 140 ksi
- Typical Elongation to Fracture: 15.5 percent
- Young's Modulus (austenite) = 75 - 83 GPa
- Young's Modulus (martensite) = 28 - 41 GPa
- Typical Yield Strength (hi-temp): 560 MPa, 80 ksi
- Typical Yield Strength (lo-temp): 100 MPa, 15 ksi
- Approximate Elastic Modulus (hi-tem): 75 GPa, 11 Mpsi
- Approximate Elastic Modulus (lo-temp): 28 GPa, 4 Mpsi
- Poisson's Ratio: 0.33

#### 2.1.3 Actuation:

- Energy Conversion Efficiency: 5%
- Work Output: ~1 Joule/gram
- Available Transformation Temperatures: -100 to +100° C

## 3. MEMS devices and SMA actuation

The main advantages of NITINOL include high power density, huge displacement, large actuation force, low operation voltage. At the same time there are many disadvantages such as complex thermo mechanical behaviour, nonlinearity, large hysteresis loop, low energy efficiency, difficult position control, degradation and fatigue problems etc. With all this disadvantages this

SMA's are used in some MEMS devices where large force and duty cycle is required.

### 3.1 Micro Cantilever

Cantilever is a device that has one end fixed and other end is free. The NiTi is sputtered over the cantilever and the cantilever bends accordingly for the temperature. The NiTi-Si cantilever was fabricated by sputtering a NiTi thin layer of 5  $\mu\text{m}$  on top of a Si cantilever beam. The silicon beam of 15  $\mu\text{m}$  in thickness was produced by traditional silicon etching technique.

The SMA cantilever can be actuated by Thermal actuation and Electro thermal actuation. The process of heating the cantilever by direct application heat and the actuation due to this is method is thermal actuation.

The process heating the material by application of electrical current or electrical potential and produce the actuation. This type of actuation is called electro thermal actuation. This applicable when the material has high electrical resistivity of the material.

The cantilever of 3267 $\mu\text{m}$  in length and 1522  $\mu\text{m}$  in width (W.M. Huang et al,2004)is used for the analysis. The cantilever was thermal



Figure 3.1: Shows the cross sectional view of the cantilever[4]

actuated . The temperature below 293.15K the cantilever bends upwards and for the temperature above the 293.17K it bends downwards.

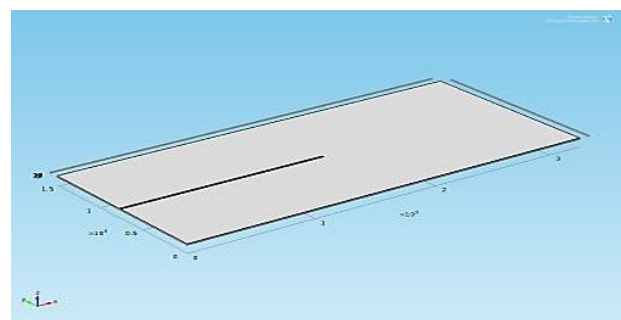

Figure 3.2 Shows the cantilever structure with the slot that is created using Femtosecond Ti:Sapphire Laser Micromachining System (W.M. Huang et al,2004).

The slot is created using the Femtosecond Ti: sapphire micromachining system to produce the resistive path for producing joule heating effect.

3.1.1 Thermal Actuation:

The temperature for the cantilever is applied from 173.15K to 393K. The temperature is varied at a regular intervals and the bending of the cantilever is observed. The iterated solutions are fine tuned to get the temperature of upward bending and the temperature of downward bending. From this for the temperature below 293.15K the NiTi-Si cantilever bends upward and for the temperature above the 293.17K the NiTi-Si cantilever bends downwards.

Then for knowing the structural dimension effect on NiTi-Si cantilever the slot length, Slot width, Slot height was varied and the stress variation is observed.

At 293.15K as the slot width is varied the stress gets increased and similarly at 293.17K as the slot width increases the stress decreases. The slot length and slot height is fixed.

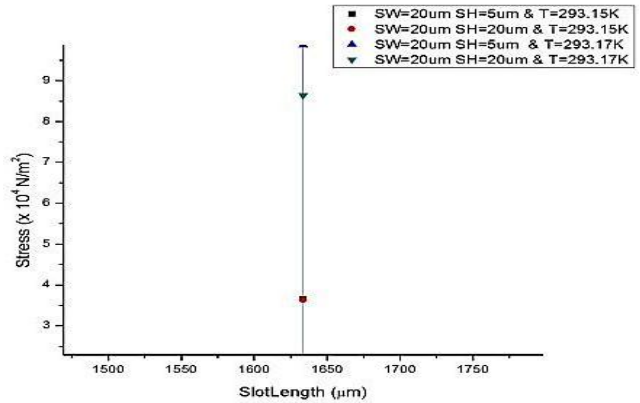

Figure 3.5 : Shows the relation between the stress and the slot height

At 293.15K as the slot height is decreased the stress gets reduced and similarly at 293.17K as the slot height is reduced stress gets increased. The slot length and slot width is fixed. As discussed before we now clearly see the variation level of stress when the temperature is applied for various slot length of the cantilever.

3.1.2 Electro Thermal Actuation:

When the electric current is applied the stress in the cantilever is distributed at the corners of the cantilever. The potential is applied for two electric current values. This current is converted to potential by using,

$$V = I \times R \quad \dots (1)$$

Where I is the current, R is the electrical resistivity.

The value of electrical resistivity R can be calculated using the following equation,

$$R = \rho \frac{L}{A} \quad \dots (2)$$

Where  $\rho$  is the resistivity of the material, L is the length of the cantilever and A is the cross sectional area of the cantilever i.e.

$$A = W \times H \quad \dots (3)$$

By using the above values the electric current is applied in form of electric potential. When applying the potential values the cantilever gets heated and starts bending due to the joule heating property.

The temperature distribution is also uneven in the structure. The temperature is maximum at the end of the cantilever. The temperature along Line 2 is fairly uniform as compared with that along Line 1. This is obvious, since Line 2 is very close to the end of the cantilever.

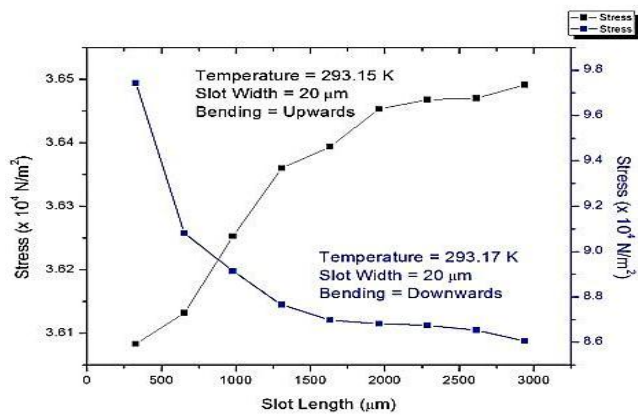

Figure 3.3 : Shows the relation between the stress and the slot length

The graph gives a brief idea how the stress changes as the slot length changes. At 293.15K as the slot length increases the stress increases and similarly at 293.17K as the slot length increases the stress gets reduced. The slot width and slot height is fixed.

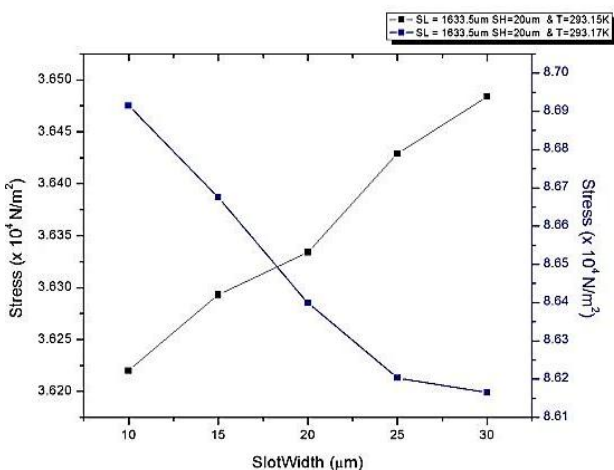

Figure 3.4 : Shows the relation between the stress and the slot width

The high temperature zone is at around the end of the slot. The temperature distribution along Line 1 is pretty symmetrical, and the highest temperature is at the middle. The cantilever initially at the upward bent position as the cantilever bends downward stress gets increased

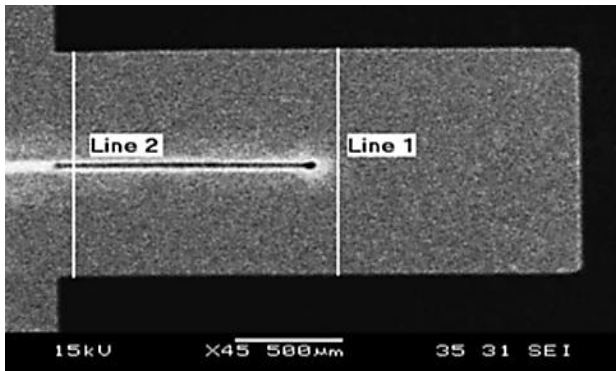

Figure 3.6 : shows the top view of the cantilever

The downward motion of the cantilever is governed by the reverse phase transformation in NiTi (large contract in NiTi layer). The difference in thermal expansion coefficient between silicon and NiTi causes a slight reverse. At 0.6mA the cantilever bends upward and the cantilever bends downward at the 0.55mA.

This bending occurs due to joule heating and the temperature that is produced at the 0.55mA is greater than 293.17K hence the cantilever bends downwards and also when 0.6mA is applied the temperature built is below 293.15K and the cantilever bends upwards.

As the temperature becomes higher, the high temperature zone is well over the transformation finish temperature. Subsequently, the NiTi film in that area (central of the bottom cantilever) starts to expand. The expansion of NiTi film at the central bottom can cause reverse bouncing, i.e. buckling, in the cantilever. The current density in the cantilever is maximum at the end of the slot where the temperature is also high.

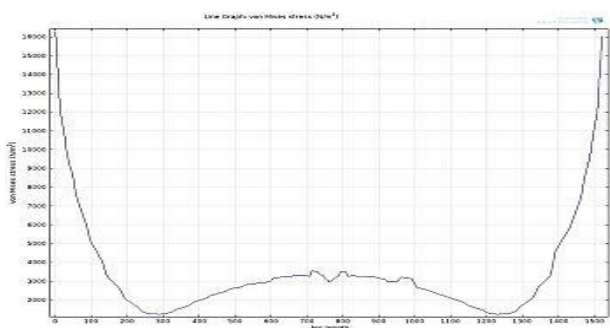

Figure 3.7 : shows the stress distribution in the cantilever at the input edge.

The graph shows the distribution of the stress in the cantilever when the electric current is applied to the NiTi layer. The current density remains the same for varied slot length and slot width. From the graph it is clear that the stress is distributed at the corners of the cantilever

structure. Similarly the stress is distributed along the length of the cantilever and more at the corners of the cantilever.

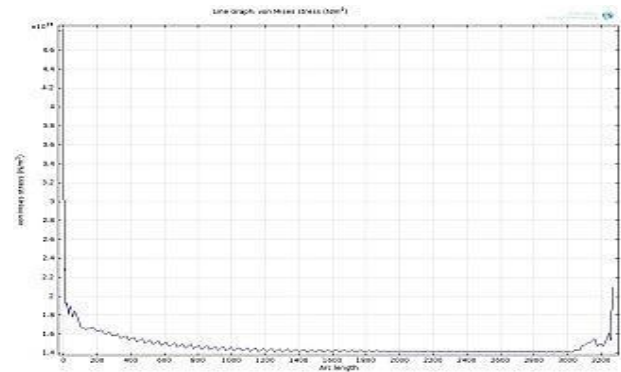

Figure 3.9 : shows the distribution of the stress along the length of the cantilever

The dynamic data substitution, the cantilever initially at the upward bent position as the cantilever bends downward stress gets increased. At 0.6mA the cantilever bends upward and the cantilever bends downward at the 0.55mA. This bending occurs due to joule heating and the temperature that is produced at the 0.55mA is greater than 293.17K hence the cantilever bends downwards and also when 0.6mA is applied the temperature built is below 293.15K and the cantilever bends upwards. The current density in the cantilever is maximum at the end of the slot where the temperature is also high. The current density is same along the various length of the slot and various slot width. By using the SMA over the Silicon cantilever the stable position of the SMA is increased i.e. there were only two stable positions in the cantilever they were high temperature state (austenite phase) and low temperature state (martensite phase), now by using this the stable positions are flat, up and down.

Under certain conditions (most importantly, geometry of cantilever), temperature difference can bring an NiTi-silicon cantilever to buckle, which causes significant reverse motion

### Conclusion

In this paper, the behaviour of a micro NiTi-silicon cantilever actuated by thermal and electrical current is reported and also the effect of structural dimensions over the micro cantilever is reported.

At 293.15K as the slot length, slot width increases the stress increases and similarly at 293.17K as the slot length, slot width increases the stress gets reduced. At 293.15K as the slot height is decreased the stress gets reduced and similarly at 293.17K as the slot height is reduced stress gets increased.

At 0.55mA the cantilever bends down as the temperature induced is more than 293.17K and at 0.6mA cantilever bends upwards as the temperature induced is 293.15K. The reported cantilever has three stable positions such flat, down and up depending on the electric current applied and this is to the non-uniform temperature distribution in the cantilever upon heating.



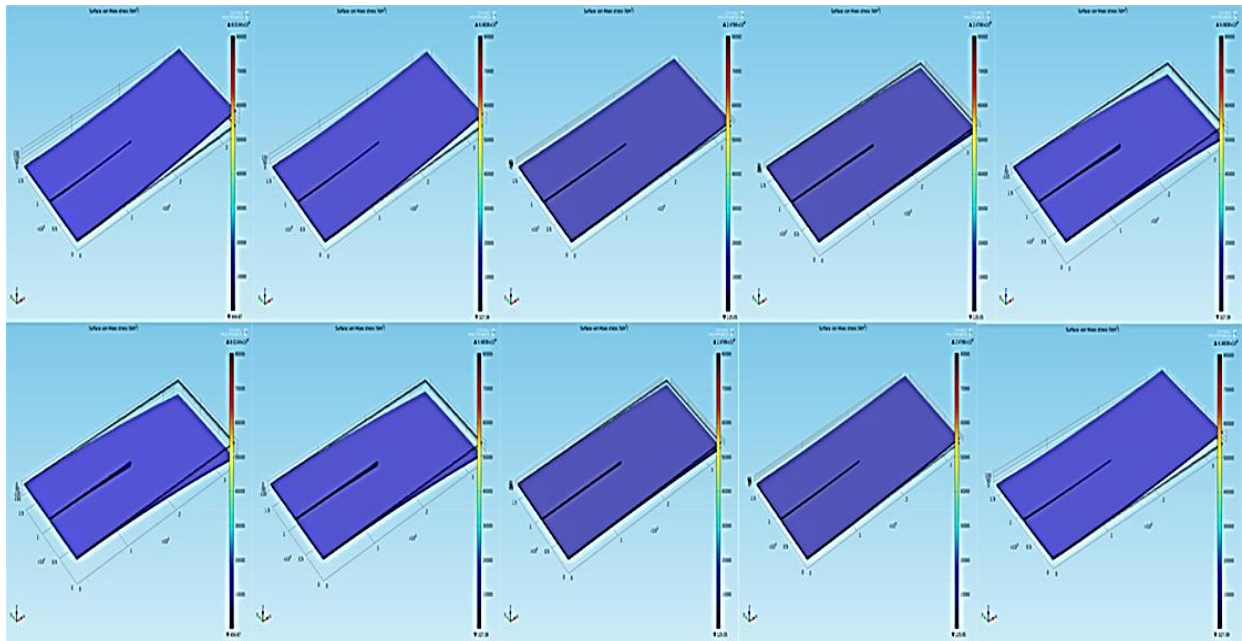

Figure 3.8 : Shows the full harmonic sequence of images of the NiTi-Si cantilever bending at the 0.6mA.

## References

- Yongqing Fu (2004), Hejun Du , Weimin Huang , Sam Zhang , Min Hu TiNi-based thin films in MEMS applications: a review, *Sens. Actuators A* 112 ,395–408.
- K. Otsuka, X. Ren (1999), Recent developments in the research of shape-memory alloys, *Intermetallics* 7, 511–528.
- J.V. Humbeeck (1999), Non-medical applications of shape-memory alloys, *Mater. Sci. Eng. A273–A275* ,134–148.
- W.M. Huang , Q.Y. Liu, L.M. He1, J.H. Yeo(2004), Micro NiTi–Si cantilever with three stable positions, *Sens. Actuators A* 114 ,118–122
- M. Kohl, E. Quandt, A. Schu'bler, R. Trapp, D.M. Allen (1994), Characterization of NiTi shape memory microdevices produced by microstructuring of etched sheets or sputter deposited film, in: H. *Borgmann, K. Lenz \_Eds., Proceedings of Actuator* 94, Bremen, Germany.,pp. 317–320.
- M. Kohl, E. Just, W. Pfleging, S. Miyazaki (2000), SMA microgripper with integrated antagonism, *Sens. Actuators A* 83 ,208–213.
- W.M. Huang, J.P. Tan, X.Y. Gao, J.H. Yeo, Design (2003), testing and simulation of NiTi shape memory alloy thin film based micro-grippers, *J. Microlithogr. Microfabrication Microsyst.* 2 ,185–190.
- T. Mineta, T. Mitsui, Y. Watanabe, S. Kobayashi, Y. Haga, M. Esashi (2001), Batch fabricated flat meandering shape memory alloy actuator for active catheter, *Sens. Actuators A* 88 ,112–120.
- Weimin Huang (March1998)., Shape Memory Alloys and their Application to Actuators for Deployable Structures, *Dissertation submitted to the University of Cambridge for the degree of Doctor of Philosophy*
- MICROSYSTEM DESIGN , Stephen D. Senturia(*Massachusetts Institute of Technology* ), eBook ISBN: 0-306-47601-0.
- SOIMUMPs Design Handbook, Allen Cowen, Greg Hames, DeMaul Monk, Steve Wilcenski, and Busbee *Hardy MEMSCAP Inc.*
- An Introduction to Microelectromechanical Systems Engineering, Second Edition, Nadim Maluf, Kirt Williams.
- Sanghaun Kim and Maenghyo Cho (2007), Numerical simulation of a double SMA wire actuator using the two-way shape memory effect of SMA, *iopscience.iop.org Smart Mater. Struct.* 16 372
- Takahiro Namazu, Akinobu Hashizume, Shozo Inoue (2007), Thermomechanical tensile characterization of Ti–Ni shape memory alloy films for design of MEMS actuator Sensors and Actuators A 139 ,178–186
- E. Shameili, A. Alasty , H. Salaarieh (2005), Stability analysis and nonlinear control of a miniature shape memory alloy actuator for precise applications, *Mechatronics* 15 471–486.
- M. Kohl, B. Krevet, E. Just, SMA microgripper system, *Sens. Actuators A* 97 -98 (2002) 646 - 652.
- Shape memory alloys and its properties; <http://www.smaterial.com>, <http://www.stanford.edu/~richlin1/sma/sma.html>
- Shape memory alloys and its properties; NITINOL and its properties , [http://en.wikipedia.org/wiki/Shape-memory\\_alloy](http://en.wikipedia.org/wiki/Shape-memory_alloy), <http://www.tinialloy.com/pdf/introductiontosma.pdf> ,
- Physical Properties of NITINOL [http://jmmedical.com/resources/221/Nitinol\\_Technical-Properties.html#nitinol-physical-properties](http://jmmedical.com/resources/221/Nitinol_Technical-Properties.html#nitinol-physical-properties)
- Convertors from electrical resistivity to electrical conductivity and conversions, <http://www.engineeringtoolbox.com>.