

Design and Manufacturing of Solar Jacket for Charging the Mobile and Laptop Devices

Uzma Syed^{a*} and Anam Memon^a

^aDepartment of Textile Engineering, Mehran University of Engineering and Technology, Jamshoro, Pakistan

Accepted 4 Nov.2012, Available online 1Dec. 2012, Vol.2, No.4(Dec. 2012)

Abstract

In this research a wearable, portable solar jacket was designed and manufactured for charging the electronic devices such as mobile phone, iPod, mp3 players and laptop. A solar panel was used to convert the solar energy into electrical energy. The solar circuit consist of solar panel; composed of two solar cells (attached in series), two ICs for controlling the voltage and rechargeable batteries for charging the devices in the absence of sunlight. The glass sheet coated solar panel was attached at the back of the jacket using sticky material. The wires and other accessories were attached inside the jacket, the batteries and charging pins were placed inside the pockets of Jacket. The designed garment not only serves the purpose of wearing but also charges the electronic devices up to +24 V. It is cheap, easy to detach, washable and gives comfort to wearer.

Keywords: E- textiles, charging garment, solar cells

1. Introduction

Extensive use of natural and renewable energy sources is needed to minimize the burden of fossil fuels. Burning of high levels of fossil fuels induce climate change, air and environmental pollution. Moreover, reason for switching from fossil fuels to renewable sources is their huge consumption and rapid reduction. A variety of renewable energy sources are readily available such as sun, wind, tides, and geothermal activity. An initial cost and maintenance cost of renewable energy is high but has no fluctuation in prices when in use as compared to the prices of electricity and gas. It is because renewable energies are fully dependent on natural energy sources, hence, eliminating the dependence on fossil fuels. In third world countries such as in Pakistan, approximately 90 percent of electricity originates from polluting sources of energy such as coal. Coal-fired power plants are responsible for pollution that increases asthma attacks and worsens environmental problems such as acid rain, haze, smog, and other air and water pollution .

Solar energy is the most promising of the renewable energy sources in view of its apparent limitless potential. In this connection solar cells are used in which the solar radiation is directly converted into electricity. The most common method of doing this is through the use of silicon solar cells (A. S. Sambo et al,2005). Sunlight is composed of photons, when photons strike a PV cell; they may be either reflected or absorbed or may pass right through. Only the absorbed photons generate electricity due to the

transference of an electron in an atom of the cell (which is actually a semi-conductor) . Different solar products have been launched such as solar chargers for cell phones and laptops and solar power for solar signals, emergency road signs, emergency call boxes, parking lights and garden lights . However, solar cell has few limitations such as its efficiency is decreased near the poles of earth, in cloudy weather and it is expensive.

Furthermore, research has been extended towards E-textiles. An integration of photovoltaic thin film cells into wearable such as jacket, tie and pocket gave new concept of fashion and smart textile (J.S Hynek et al). These solar cells are graphically strong and need to be more visually integrated into the garment. Different solar jackets have been introduced in Japan and other countries. These jackets were capable of charging at low voltage such as cell phones only. Solar bags for charging laptops, cell phone and iPod were also introduced. Solar caps were also introduced and commercialized too(J. Schaeffer et al,2005). In addition, solar panels were attached in dresses such as bathing suits for charging cell phones and other devices with USB port.

Hence, it has been observed much work has been carried out on replacing the conventional energy system with the solar energy and use of solar energy in garments. Therefore, in this research a flexible and portable charging garment using solar energy system was designed. The garments can charge mobile phones, iPod, laptop and other devices that work up to +24 V. The design garment is cheap, portable, washable, comfortable and safe (no risk of electric shocks). The fitting of solar panel was done in

*Corresponding author's email: uzma.syed@faculty.muett.edu.pk

such a way that optimum amount of heat via sunlight can pass through the panel and generate maximum energy. However, the solar circuit can be attached in a variety of styles in the garment such as on pant pockets and pockets on sleeves.

The design jacket has flexibility; it can be used for windy and harsh weather condition because of glass sheet coated on solar panel. For making jacket more flexible, small wafer solar cell can be used but this type of garment requires clean environment and weather.

Design Methodology

For designing the solar jacket; solar cell, ICs, rechargeable batteries and ready-made jackets were used. The solar cells (2 sets) each of 12 V were connected in series. It senses the sunlight and generate the DC voltage. Two ICs were used for charging the mobile, iPod, mp3 player and laptop and work as a charge controller. There were four rechargeable batteries (each of 4 V and 1.2 A) connected to store the electric charges and can be used to charge the devices in the absence of sunlight. A reverse diode was also attached for one way passage of current.

the wearer. Further, if it is attached below this level, it would affect the appearance of the garment and also exposure to sunlight would be affected the life of circuit. Other accessories of solar panel such as wires were attached using the small pins. A zip as shown in fig 3 was used to hide and cover the circuit and wires. The detachable ports were used to connect the charger pins; that were placed at right hand side pocket (see fig 4). Similarly, the rechargeable batteries were placed at left hand side pocket (see fig 5). The front and back view of jacket is shown in fig 6. It has been observed that the stitched solar panel is easy to detach when required such as for washing the jacket (see fig 7).

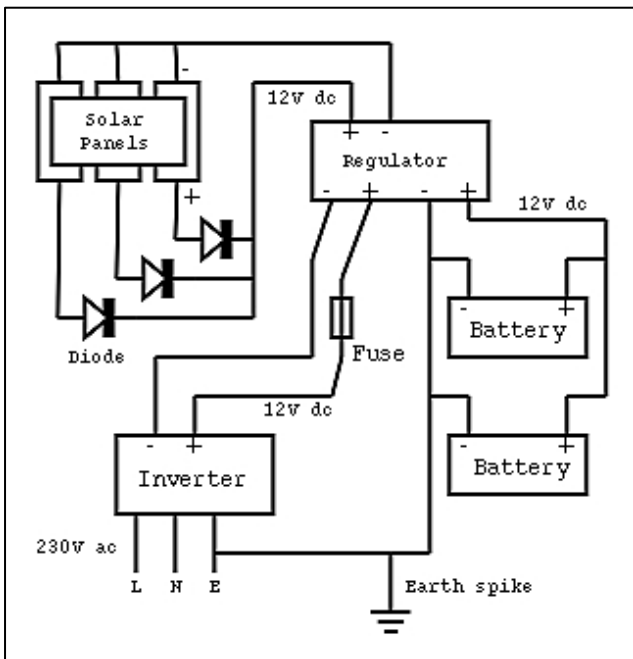

Figure 1 Solar Circuit

The solar panel of 13*5 inches was sealed using glass sheet coating. For attaching the solar panel along with other accessories (circuit as shows in fig 1), a hole of 2*1.5 inches was cut for solar panel and 8.5*8.5 inches was cut for wires inside the jacket. Through the hole, wires and ports were passed into the first layer of garment. Whereas, panel was attached at the back of the jacket using sticky gum, 3 inches below the shoulders as shows in fig 2. The distance 3 inch was selected; because at that distance it has optimum exposure to sunlight and comfortable for wearer. If the solar panel is attached near to the neck, it irritates



Figure 2 Solar panel attached at the back

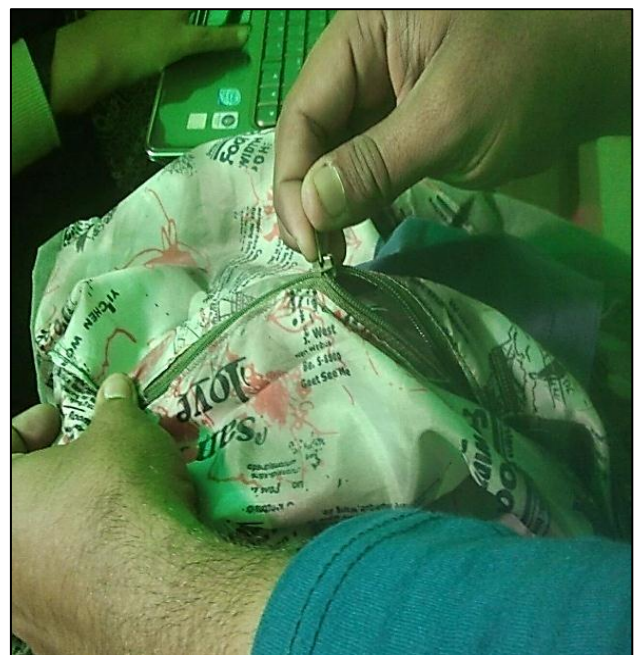

Figure 3 Zip to hide and cover panel wiring



Figure 4 Cell phone and laptop charging pins



Figure 7 Detachable solar panel



Figure 5 Rechargeable batteries

Assessment

This garment can charge both laptop and cell phone at a time (see fig 8 and 9). The wearable charging garment charges the cell phone in the same time as the normal charger does i.e. 1 to 1.5 hours. For charging any of the devices such as cell phone, laptop, mp3 player, iPod etc, the wearer need not to stand under the sun continuously. There are rechargeable batteries attached in the circuit which store the electric charges and use in the absence of sunlight.



Figure 6 Jacket front and back view



Figure 8 Mobile being charged by solar jacket



Figure 9 Laptop being charged by solar jacket

Conclusion

This paper is a step towards the solution of energy crisis for third world countries such as Pakistan. Renewable energy, free of cost is used to overcome energy crises. Utilizing of solar energy for charging devices in the garment is a great achievement. The designed portable garment can charge different electronic devices (laptop, mobile, iPod and mp3 players) in the absence of electrical energy. It is cheap, compact, comfortable and instantly available charging device. Electronic items is plugged in and charged, allowing power most of the devices less than

or equal to +24 V. Time is taken to charge the mobile and laptop is same as taken by home charger. Moreover, two devices (mobile and laptop) can be charge simultaneously.

Acknowledgment

The authors acknowledge the co-operation of Mr Ali Raza for his guidance in designing of project.

References

- Natural and Renewable Energy, <http://www.clean-energy-ideas.com/>,2007-2012, [accessed on February 09, 2012]
- A. S. Sambo and et al (2005), Renewable energy for rural development: the Nigerian perspective, *ISESCO Science and Technology Vision*, 1, 17.
- How A Photovoltaic Cell Works, <http://inventors.about.com/library/inventors/blsolar3.html>, [accessed on February 14, 2012]
- How Solar Power Works? <http://www.solarpowernotes.com/how-solar-power-works.html>, [accessed on February 11, 2012]
- J.S Hynek, J.R. Campbell, and K.M. Bryden, Application of digital textile printing technology to integrate Photovoltaic thin film cells into wearables, *Journal of Textile and Apparel Technology and Management*, .
- The solar handbag, <http://www.bemoreeco.com/tag/solar-handbags/>, [accessed on March 02, 2012]
- J. Schaeffer (2005), Solar hot fan, *The real goods solar living*, 12th edition, Hopland, California, pp 252.
- Solar Bikini, The swimsuit that can make you stay connected, solarcellssale.info/news-solar-cells/solar-bikini-swimsuit-make-stay-connected.html, [accessed on March 02, 2012]