

Research Article

Voltage Flicker Estimation and Mitigation of Voltage Controlled DG Grid Interfacing Converters with Wind Power Source

Sujin P. R^a, T. Ruban Deva Prakash^{b*}, L. Padma Suresh^c

^a Noorul Islam University, Kumaracoil.

^b MET'S School of Engineering, Mala

^c Noorul Islam University, Kumaracoil.

Accepted 8 April 2012, Available online 1 June 2012

Abstract

The necessity for flexible electric systems, changing regulatory and economic scenarios are providing impetus to the development of Distributed Generation (DG), which is predicted to play an increasing role in the electric power systems of the future. The use of distributed generation (DG) in distribution system is expected to increase in the near future due to its positive impacts such as voltage support, improved reliability, small size and losses reduction. With so much new DG being installed, it is essential that the effects on power systems be assessed accurately so that DG can be applied in a manner that avoids degradation of power quality. Distribution generators with wind power source cause voltage flicker problems which degrade the power quality. However, if controlled and regulated properly, the DG grid interfacing converters are able to improve the distribution system efficiency and power quality. This study investigates the impact of DGs on voltage flicker which is considered recently as an urgent power quality problem that can affect motor starting, temperature rise, overloading of generators, motors and may cause health risk problems due to the annoying light flicker which is consequence of voltage fluctuation. This paper also focuses on the distribution system voltage flicker control, through the DG grid interfacing converters. A novel flicker control scheme using a voltage-controlled method is developed in this paper. This control algorithm is based on instantaneous real and reactive power method which compensates current harmonics in addition to flicker mitigation. The voltage-controlled method is more flexible and has similar compensation performance compared to the conventional current-controlled method. In addition, the proposed voltage based method can be seamlessly incorporated into a voltage-controlled DG unit, which is important to provide direct voltage and frequency support in a micro-grid.

Keywords: Voltage flicker, Distributed Generators (DG), instantaneous real and reactive power method, Voltage controlled method, micro-grid.

1. Introduction

Power quality is the term used to describe how closely the electrical power delivered to customers conforms to the appropriate standards in operating their end-use equipment correctly. Thus, it is essentially a customer-focused measure although greatly affected by the operation of the distribution and transmission network. There are number of ways in which the electric supply can deviate from the specified measures. These range from transients and short duration variations to long-term waveform distortions. Sustained complete interruptions of supply are generally considered as an issue of network reliability rather than power quality. The growing importance of power quality is due to the increasing use of sensitive load equipments including computer-based controllers and power electronic converters (Working group of UIE, 1992). Besides, the

customers are well aware of the commercial consequences of disturbances originating on the power system. Most industries and commercial establishments are affected by power quality (PQ) problems (Mohammad S. Azam et al., 2004). Power quality has attracted considerable attention from both utilities and users, due to the use of many types of sensitive equipment. Performance of these equipments are affected by harmonics, voltage sag- swell, voltage flicker and load frequency variations. These disturbances cause problems, such as overheating, equipment failures, inaccurate metering and malfunctioning of protective equipments etc.

In recent years, Distributed Generation (DG) gained much attention due to its widespread use and the expectation of the increase of using these DGs in the future especially as the electric power market is undergoing liberalization. Some studies (Lasseter.R.H, 1998) show that within the next two or three years, distributed generation may represent up to 30% of all new

* Corresponding author's email: mahiruban2006@yahoo.co.in

generation. There is a great consensus on the positive impacts of these DGs on the electric distribution systems (Chaitusaney.S et al., 2006). Some of these positive impacts are voltage support, improved reliability, line loss reduction, and transmission and distribution capacity release. Moreover, Distributed generation has lower capital cost because of the small size, also renewable energy based DGs (such as wind or solar) can produce near zero pollutant emissions (Kashem.M et al., 2006). DGs can operate as backup in case of interruption, or for peak shaving during time of high demand, or as net metering for feeding power back into the distribution system (Brown.R et al., 2001). However, the negative impacts of distributed generation include some operating conflicts for fault clearing, reclosing and interference with relaying (14). Also islanding (where a portion of the utility system that is disconnected from the remainder of the utility system while it is still being energized from distributed resources (IEEE Std. 929-2000)) may occur, leading to poor power quality for this portion and voltage rise which may damage the customers' equipments. Other negative effects on power quality include harmonic distortion due to power electronic converter interface, voltage regulation problems due to lack of coordination between DGs and utility voltage regulation equipments.

Voltage flicker become a power quality problem in recent years. It is defined as "an impression of unsteadiness of visual sensation induced by a light stimulus, whose luminance or spectral distribution fluctuates with time". The effect of voltage flicker is that it may affect the starting torque, slip, starting current and temperature rise. Moreover, it can lead to overloading of generators and motors, reduces the lifetime of the electronic, incandescent, fluorescent and CRT devices (Zheng.T et al., 1998). Since voltage flicker phenomena is related to voltage magnitude fluctuation for frequency change from 0.5 to 30 Hz, it has been reported that this may affects the visual perception of light which represents a health risk problem for people who are prone to epilepsy (Chau-Shing.W et al., 2004). The known sources of voltage flicker are arc furnaces, welders, rolling mills, Variable Frequency Drives (VFD) generating inter-harmonics, switching loads and motor starting including elevators, fans and pumps. Also variations in the load current due to repetitive events such as air conditioners, washers, refrigerators, photocopiers and dryers may cause voltage flickers.

Voltage flicker mitigation depends on reactive power control. Two types of structures can be used for the compensation of the reactive power fluctuations which are shunt structure and series structure (B. P. Roberts, 2002; G. C. Montanari et al., 2003). In the shunt type of compensation, the reactive power consumed by the compensator is kept constant at a sufficient value. In the series structure, all the efforts are done to decrease the voltage drop mentioned above, and finally the reactive power is kept constant despite the load fluctuations by controlling the line reactance. In addition to the aforesaid procedures for the compensators, the active filters are used for the voltage flickers mitigation as well (J. Dolezal et al.,

2005). Furthermore, the mitigating devices based on Static VAR Compensator (SVC) such as Thyristor Switched Capacitor TSC, Thyristor Controlled Reactor (TCR), and Fixed Capacitor Thyristor Controlled Reactor (FCTCR) are the most frequently used devices for reduction in the voltage flicking. SVC devices achieved an acceptable level of mitigation, but because of their complicated control algorithms, they have problems such as injecting a large amount of current harmonics to the system and causing spikes in voltage waveforms. In this respect, the FACTS devices based on voltage-source converters have been able to improve the problems related to SVC. Flicker compensation in arc furnace power systems using the DVR is explained by Sedraoui.K et al., 2011.

The control strategy adopted to mitigate flicker plays a key role for effective mitigation. Different control algorithms for flicker mitigation are presented in (J. Dolezal et al., 2005). A new technique based on a novel control algorithm, which extracts the voltage disturbance to suppress the voltage flicker, is presented by R. Mienski et al., 2009 and Amit K et al., 2010. The technique is to use DSTATCOM for voltage flicker compensation to overcome the aforementioned problems related to other techniques. The concept of instantaneous reactive power components is used in the controlling system. The design and control strategy based on the instantaneous power calculation are detailed by Sedraoui.K et al., 2011.

In this paper, the effect of distributed generation on voltage flicker has been studied. This paper also focuses on the distribution system voltage flicker estimation and control, through the DG grid interfacing converters. A novel flicker control scheme using a voltage-controlled method is developed in this paper. The voltage-controlled method is more flexible and has similar compensation performance compared to the conventional current-controlled method. In addition, the proposed voltage based method can be seamlessly incorporated into a voltage-controlled DG unit, which is important to provide direct voltage and frequency support in a micro-grid.

2. Power electronics interface for DGs with wind power source

Since the fastest growing renewable energy source is the wind power, the main focus here will be on DGs utilizing wind energy sources. Basically, the electrical systems of these DGs are divided into three categories:

- Systems without power electronics, at which a fixed speed wind turbines are connected to the grid through induction generators.
- Systems with partially rated power electronics interface.
- Systems with full-scale power electronics interface.

Variable speed wind turbines are utilized in systems with power electronics interface. Normally, these turbines are controlled in such a way to capture the maximum power by varying the rotor speed. They have the advantages of reducing stresses of the mechanical structure and acoustic noise reduction. Wind turbines with partially rated power electronics interface have the

advantages of reduced switching losses over full rated ones. However, in full-scale power electronics interface the main advantages are that the generator is decoupled from the grid through the DC-link and the power converter at the grid side enables a fast control over active and reactive powers. A typical variable speed wind turbine system with full-scale power converters is shown in figure 1, at which the wind turbine is connected through a gear-box to an induction generator (G). The benefit of using the induction generator instead of synchronous generator is to reduce the system size since the latter needs a small power converter for field excitation. The output of the generator is then rectified and the resulting power is transferred through a DC link to a voltage source converter. Voltage source converters (VSCs) implementing isolated gate bipolar transistor (IGBT) switches that are controlled by pulse width modulation (PWM) are used on the grid side for their high controllability and power quality. However, the drawback of using VSCs is their sensitivity to voltage disturbances, e.g. voltage dips. Typically, filter inductors (L-filters) are used to minimize the current harmonics injected into the grid. Another main drawback of this setup is the speed variation of generator due to variation of wind speed. This speed variation causes variation in frequency. Frequency variation is one of the sources of voltage flicker. Minor power disruptions, which once would have been noticed only as a momentary flickering of the lights, may now completely interrupt whole automated factories because of sensitive electronic controllers or make all the computer screens at an office go blank at once. In order to restart the whole production, computers, etc, a considerable time might be necessary, implying on significant financial losses to an industry. Hence voltage flicker caused by frequency variations of DG is considered as a major power quality issue which is to be settled efficiently.

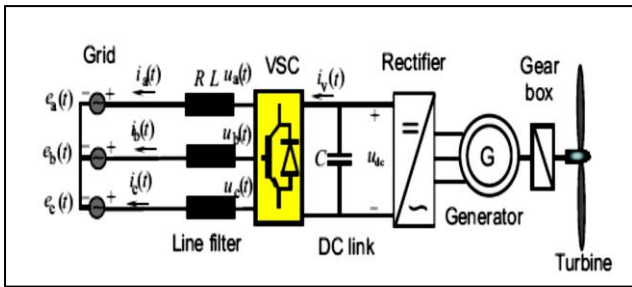

Fig. 1 Power electronics interface for DGs with wind power source

3. Grid-Connected Voltage Source Converter with L-filter Interface

Voltage source converters (VSCs) are generally preferred over current source converters in grid-connected converter applications. This is mainly justified by the introduction of power-electronics devices (such as IGBTs in distribution level) with self turn-off capabilities, and also the advantages of capacitive DC storage over an inductive one in terms of weight, cost and efficiency. VSC's are, for

example, employed in shunt or series compensators. Shunt-connected VSC's are also utilized in the medium voltage (or distribution grid) as interface to distributed generation (DG) or in electric drives applications. In these applications, the DC-link voltage needs to be regulated to the nominal value. The DG considered in this work is used as backup power source for improving reliability of the system. It is observed that during the period where DG is connected, the voltage flicker is more which is to be tackled carefully by adopting proper control measures. The arc furnaces, welding machine, air conditioners etc. also causes voltage flicker. This grid connected voltage source converter shown in figure 2 can be used for flicker mitigation. This research work aims at developing efficient control algorithm for flicker mitigation using voltage controlled DG grid interfacing converters with wind power source.

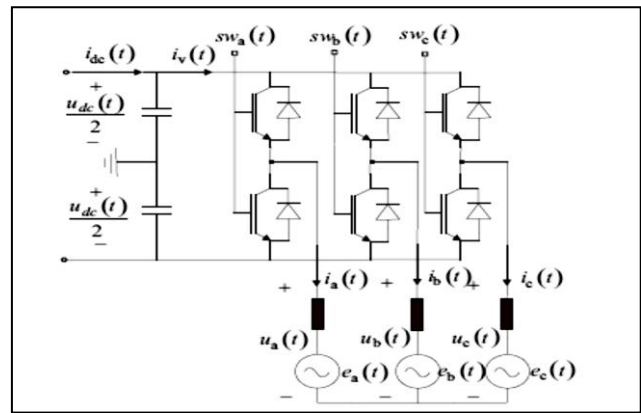

Fig. 2 Grid-Connected Voltage Source Converter with L-filter Interface

4. Voltage flicker mitigation

The three phase voltage and current in abc reference frame are converted to α - β reference frame using equations (1) and (2). Then P and Q are calculated using equation (3). The oscillating components of P and Q are separated using LPF shown in figure 3 and is used as reference for PWM controller. The PWM controller generates firing pulses for Voltage controlled grid connected DG for mitigating flicker. This control algorithm is based on instantaneous real and reactive power method which compensates current harmonics in addition to flicker mitigation.

$$\begin{bmatrix} V_o \\ V_\alpha \\ V_\beta \end{bmatrix} = \sqrt{\frac{2}{3}} \begin{bmatrix} \frac{1}{\sqrt{2}} & \frac{1}{\sqrt{2}} & \frac{1}{\sqrt{2}} \\ 1 & -\frac{1}{2} & -\frac{1}{2} \\ 0 & \frac{\sqrt{3}}{2} & -\frac{\sqrt{3}}{2} \end{bmatrix} \begin{bmatrix} V_a \\ V_b \\ V_c \end{bmatrix} \tag{1}$$

$$\begin{bmatrix} I_o \\ I_\alpha \\ I_\beta \end{bmatrix} = \sqrt{\frac{2}{3}} \begin{bmatrix} \frac{1}{\sqrt{2}} & \frac{1}{\sqrt{2}} & \frac{1}{\sqrt{2}} \\ 1 & -\frac{1}{2} & -\frac{1}{2} \\ 0 & \frac{\sqrt{3}}{2} & -\frac{\sqrt{3}}{2} \end{bmatrix} \begin{bmatrix} I_a \\ I_b \\ I_c \end{bmatrix} \tag{2}$$

$$\begin{bmatrix} P \\ Q \end{bmatrix} = \begin{bmatrix} V_\alpha & V_\beta \\ -V_\beta & V_\alpha \end{bmatrix} \begin{bmatrix} i_\alpha \\ i_\beta \end{bmatrix} \quad (3)$$

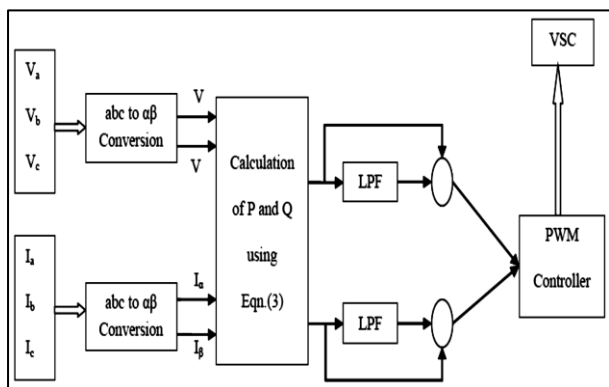

Fig. 3 Block diagram of control algorithm for voltage mitigation of voltage controlled DG

5. Simulation Study

The proposed flicker control strategies are verified through Matlab/Simulink on a 5-kVA grid connected DG system. In the simulation the nonlinear load at the PCC is a three-phase diode rectifier with parallel-connected capacitor (1000µF) and resistor (25Ω) at the dc side. The system parameters used in the simulation are listed in Table 1. The PCC voltage, DG phase voltage and DG current of grid connected voltage controlled DG without flicker compensation is shown in figure 4. From the simulation results, it is evident that DG phase voltage has flicker above limits. But with the proposed flicker control strategy, the DG phase voltage becomes smooth which is shown in figure 5.

Table 1 System parameters for simulation

Parameters	Values
Grid voltage	104V, 50Hz (3 phase)
DC link voltage	260V
LC filter	L=1.25mH, C=40µF
DG impedance	R=1Ω, L=1.25mH
Grid impedance	R=1Ω, L=1.25mH
Switching frequency	12KHz
Power reference	P*=300W, Q*=125Var

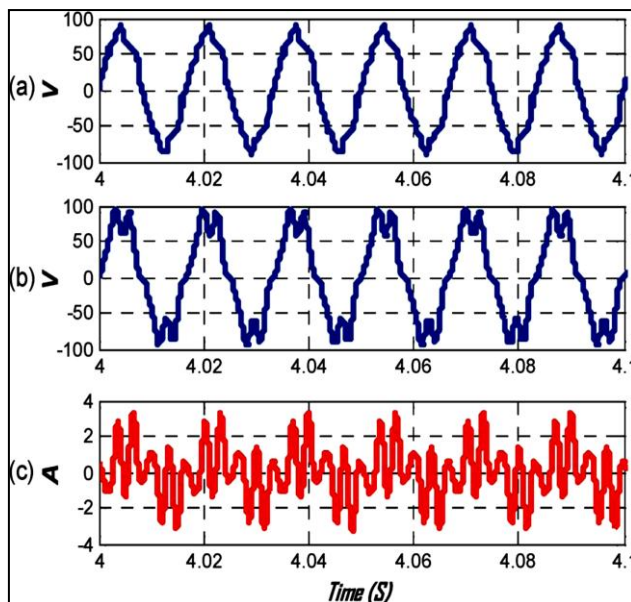

Fig. 4 Grid connected voltage controlled DG without flicker compensation (a) PCC voltage (b) DG phase voltage (c) DG current

Also, the voltage flicker variation in the presence of DG and without DG is studied. The results are shown in figure 6 and figure 7. In figure 6, DG is connected at the end of monitoring period where the range of flicker is 0.13 and during other periods without connecting DG, the flicker range is well below 0.09. In figure 7, DG is connected at the beginning of monitoring period alone where the range of flicker is 0.115 and during other periods without connecting DG, the flicker range is well below 0.09. From the results it is evident that the period where the DG was connected to supply the loads was found to have the largest frequency deviations and at the same time the voltage flicker crosses the allowed limits.

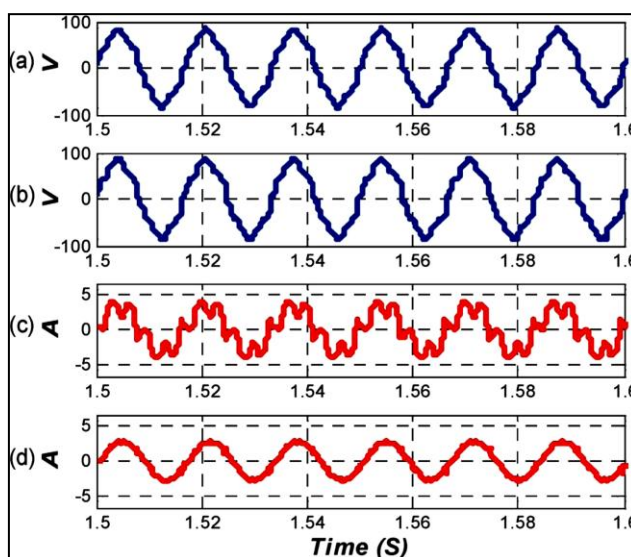

Fig. 5 Grid connected voltage controlled DG with flicker compensation (a) PCC voltage (b) DG phase voltage (c) DG current (d) Grid current

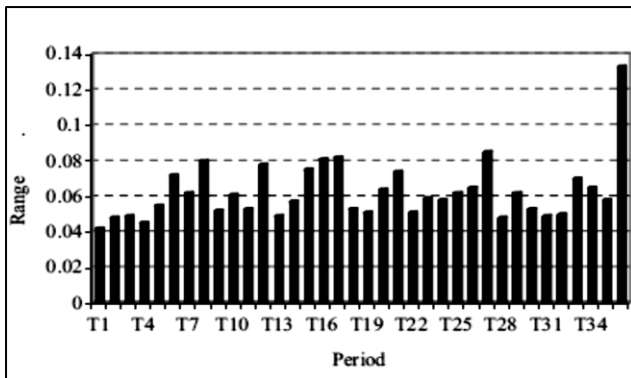

Fig. 6 Flicker range when DG is connected at the end of monitoring period

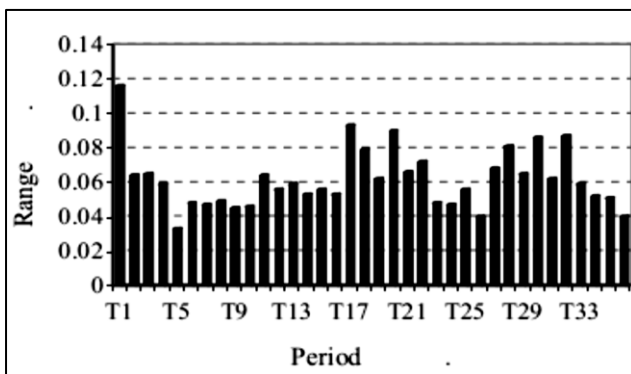

Fig. 7 Flicker range when DG is connected at the beginning of monitoring period

6. Conclusion

The main challenge facing the application of distributed generation in distribution power system is their impacts on power quality. This paper has discussed the opportunities of distribution system power quality improvement using the DG interfacing inverters. The periods where the DG was connected to supply the loads was found to have the largest frequency deviations and at the same time the voltage flicker crosses the allowed limits. Therefore it is recommended to apply suitable flicker mitigation technique. A novel flicker control scheme using a voltage controlled method is developed in this paper. This control algorithm is based on instantaneous real and reactive power method which compensates current harmonics in addition to flicker mitigation. The voltage-controlled method is more flexible and has similar compensation performance compared to the conventional current controlled method. In addition, the proposed voltage based method can be seamlessly incorporated into a voltage controlled DG unit, which is important to provide direct voltage and frequency support in a micro-grid. The proposed flicker control method has been verified by simulation.

References

- Mohammad S. Azam, Fang Tu, Krishna R. Pattipati, Fellow, IEEE, and Rajaiah Karanam (2004), A Dependency Model-Based Approach for Identifying and Evaluating Power Quality Problems, *IEEE Transactions On Power Delivery*, Vol. 19, No. 3, pp 1154-1166.
- Lasseter.R.H (1998), Control of distributed resources, *Proceedings of Bulk Power Systems Dynamics and Control IV, Restructuring, organized by IREP and National Technical University of Athens, Santorini, Greece*, pp.323-329.
- Chaitusaney.S and A. Yokoyama (2006), Contribution of distributed generation to voltage regulation under stochastic attribute of renewable energy resources, *IEEE International Conf. on Power System Technology, Power Conference*, pp. 1-8.
- Kashem.M, A. D. T. Le, M. Negnevitsky and G. Ledwich (2006), Distributed generation for minimization of power losses in distribution systems, *IEEE Power Engineering Society Summer Meeting*, pp. 8-15.
- Brown.R and L. Freema (2001), Analyzing the reliability impact of distributed generation, *IEEE Power Engineering Society Summer Meeting*, vol. 2, pp. 1013-1018.
- El-Samahy.I and E. El-Saadany (2005), The effect of DG on power quality in a deregulated environment, *IEEE Power Engineering Society General Meeting*, vol. 3, pp. 2969-2976.
- IEEE Recommended Practice for Utility Interface of Photovoltaic (PV) Systems, IEEE Std. 929-2000, Apr. 2000.
- Zheng.T and E. Makra (1998), Wavelet representation of voltage flicker, *Electric Power Systems Research*, vol. 48, no. 2, pp. 133-140.
- Chau-Shing.W and M. Devaney (2004), Incandescent lamp flicker mitigation and measurement, *IEEE Trans. on Instrumentation and measurement*, vol. 53, no. 4, pp. 1028-1034.
- Roberts.B.P (2002), Power Quality Solution Alternatives for Low and Medium Voltage Continuous Process Loads, *IEEE Rural Electric Power Conference*, pp. 4-17.
- Montanari.G.C, M. Loggini, L. Pitti, E. Tironi, D. Zaninelli (2003), The effects of series inductors for flicker reduction in electric power systems supplying arc furnaces, *IEEE Industry Applications Society Annual Meeting*, Vol.2, pp.1496-1503.
- Dolezal.J, A. G. Castillo, V. Valouc (2005), Topologies and control of active filters for flicker compensation, *International Symposium on Industrial Electronics, IEEE Proceedings*, Vol.1, pp. 90-95.
- Sedraoui.K., Al-haddad, K.,Olivier, G. (2011), Flicker Compensation in Arc Furnace Power systems Using DVR, *IEEE International Symposium on Industrial Electronics*.
- Miensi.R, R. Pawelek, I. Wasia (2009), Shunt Compensation for Power Quality Improvement using a STATCOM controller: Modelling and simulation, *IEE Proc.-Gener. Transm. Distrib.*, No.2,Vol.151, pp. 274-280.
- Amit K. Jain, Aman Behal, Ximing, Darren M. Dawson, Ned Mohan (2010), Nonlinear Controller for Fast Voltage Regulation Using STATCOMs, *IEEE Transaction on control systems technology*, No.6, Vol.12, pp. 827-842.